

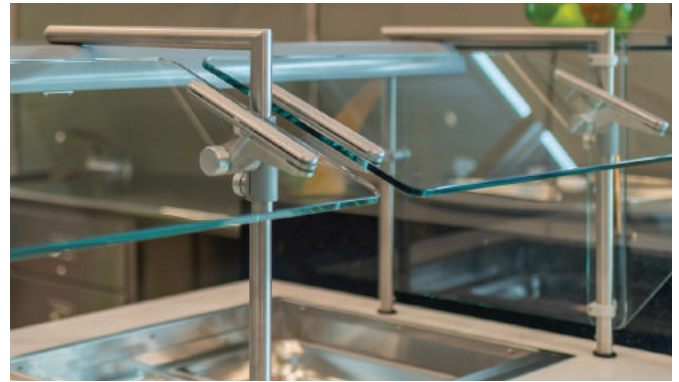

# ADVANCE GUARD™

The New Standard  
for Functionality



## THE ADVANCE GUARD ADVANTAGE

BSI's Advance Guard sets the new standard for functionality. Until now, food guards simply allowed you to move the glass panels up and down and change their angle. Advance Guard also lets you move the glass back and forth more than 3.5 inches, which means you can position it exactly where you want it. ***No other food guard gives you as much flexibility and control.***

### ADVANCE GUARD FEATURES

- Adjustable glass height, angle and front to back position
- Flexible layout options
- Quickly adapts to any health code
- Shortest lead times in the industry
- Easily fits radius or unique counter shapes
- Quick and easy installation
- No special tools needed for height or angle adjustment
- Mounts to any counter or cart
- Bracket can easily be disassembled from the post
- NSF Listed
- UL Listed
- Easy to clean and maintain
- Solid, high-quality precision die-cast components

Contact BSI or visit our website for Advance Guard product options and spec sheets — including both CAD and Revit files.



# ADVANCE GUARD™

The New Standard  
for Functionality

## IT'S TIME FOR A CHANGING OF THE GUARD

As the new standard in food guard development, Advance Guard brackets allow one person to easily adjust food shield height, reach and angle of glass — with no need for assistance from a second person.

### ADVANCE GUARD MECHANICS

*Simple, easy to turn knobs and levers are within reach— allowing for smooth movement and a wide range of bracket positioning on the posts.*

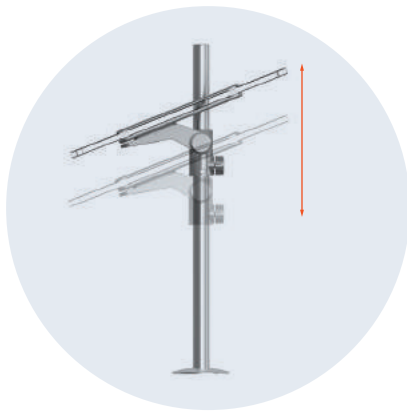

Adjust glass up and down

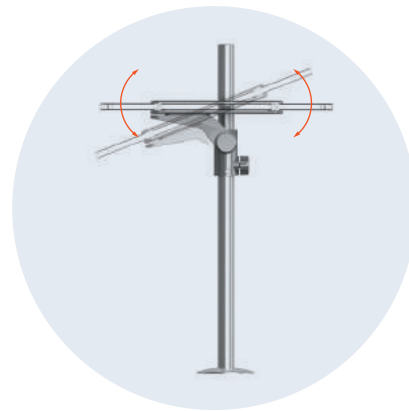

Adjust glass angle 360°

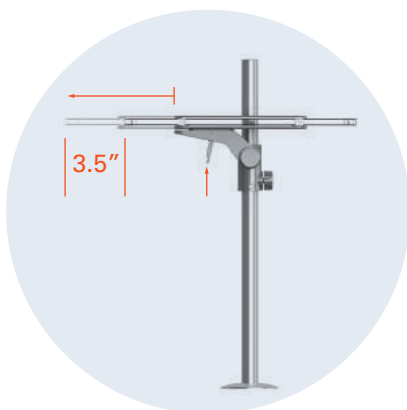

Extend glass up to 3.5"

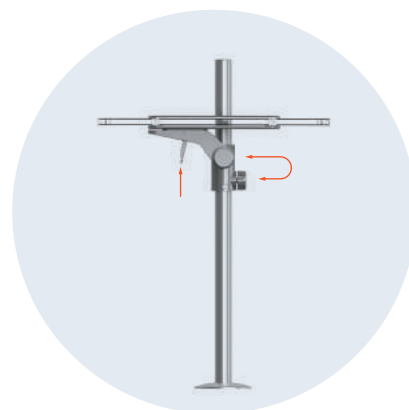

Easy bracket removal



FCSI The Americas has selected BSI's newest food shield, Advance Guard as one of 10 finalists for their Innovation Showcase to be featured at their annual conference. The Innovation Showcase is designed to recognize manufacturers whose commitment to research and development has resulted in a truly innovative product that is a clear leap forward for the foodservice industry.