

GENERAL INFORMATION

Project Name: _____

STANDARD FINISH

Brushed Aluminum

GLASS THICKNESS

1/4" Tempered Glass (not for shelves)
Centerline Max 54"

3/8" Tempered Glass (for shelf or span more than 54")
Centerline Max 66"

1/2" Tempered Glass (for shelf or span more than 66")
Centerline Max 72"

GLASS CORNERS

1" Radius Corner (standard)

Square Corners

AG2560-2

Front Counter Operator-Serve Partition

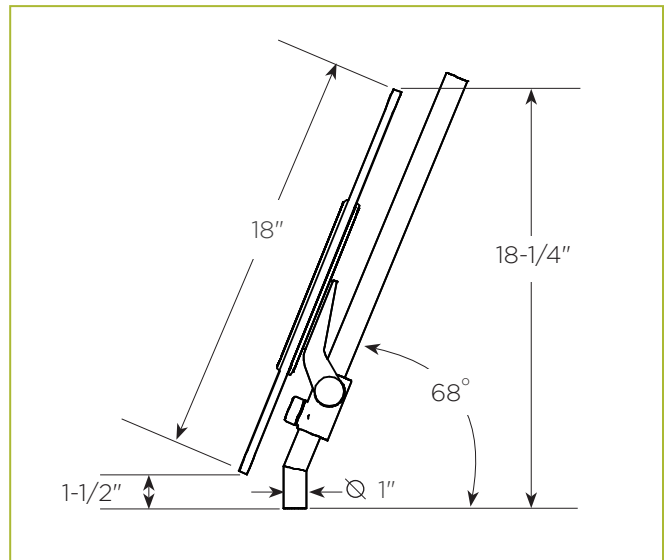
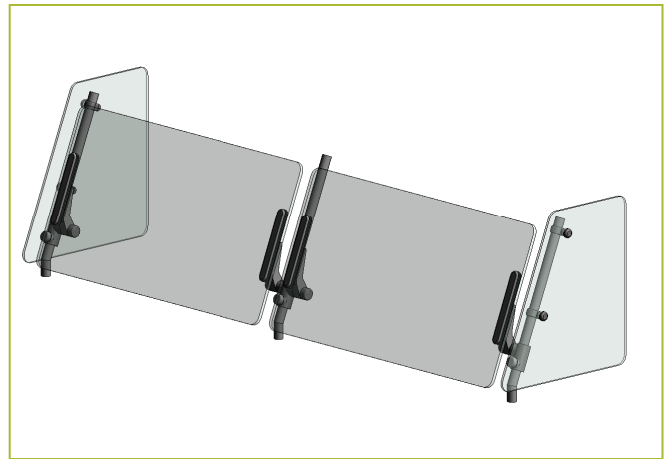

To meet NSF guidelines, end panels are included on all BSI quotations unless specifically excluded. (See end panel page for more details.)

INSTALLATION OPTIONS

(See Installation Page for more details.)

Above-Counter: Stainless Steel Counter
SS1: EZ Mount 2" x 8" Flange

Above-Counter: Millwork Counter

MW1: Heavy-Duty Flange (3-1/2" Dia.)

MW2: Narrow Flange (1-1/4"x3")

Under-Counter: Stainless Steel Counter*
SSU3-H: Heavy-Duty Flange (3-1/2" Dia.)

Under-Counter: Millwork Counter

MWU4: Compression Installation
(not recommended for solid surfaces)

SSU3-N: Narrow Flange (1-1/4"x3")

MWU5: Heavy-Duty Flange (3-1/2" Dia.)

SSU5-H: Heavy-Duty Flange (3-1/2" Dia.)

SSU5-N: Narrow Flange (1-1/4"x3")

* Requires Under-Counter Reinforcement and Access.

Approval Drawings Required

Specifications subject to change without notice.

U.S. patent information is on file at BSI, LLC and available upon request.

