

## GENERAL INFORMATION

Project Name: \_\_\_\_\_

## STANDARD FINISH

Brushed Aluminum

## GLASS THICKNESS

1/4" Tempered Glass (not for shelves)  
Centerline Max 54"

3/8" Tempered Glass (for shelf or span more than 54")  
Centerline Max 66"

1/2" Tempered Glass (for shelf or span more than 66")  
Centerline Max 72"

## GLASS CORNERS

1" Radius Corner (standard)

Square Corners

## LIGHT OPTIONS

LED Light Unit

Linear T-5 Fluorescent Unit

*For warmers contact BSI factory.*

## INSTALLATION OPTIONS

(See Installation Page for more details.)

Under-Counter: Stainless Steel Counter\*

SSU3-H: Heavy-Duty Flange (3-1/2" Dia.)

SSU3-N: Narrow Flange (1-1/4"x3")

SSU5-H: Heavy-Duty Flange (3-1/2" Dia.)

SSU5-N: Narrow Flange (1-1/4"x3")

\* Requires Under-Counter Reinforcement and Access.

Under-Counter: Millwork Counter

MWU4: Compression Installation  
(not recommended for solid surfaces)

MWU5: Heavy-Duty Flange (3-1/2" Dia.)

## AG2915 Combo-Serve

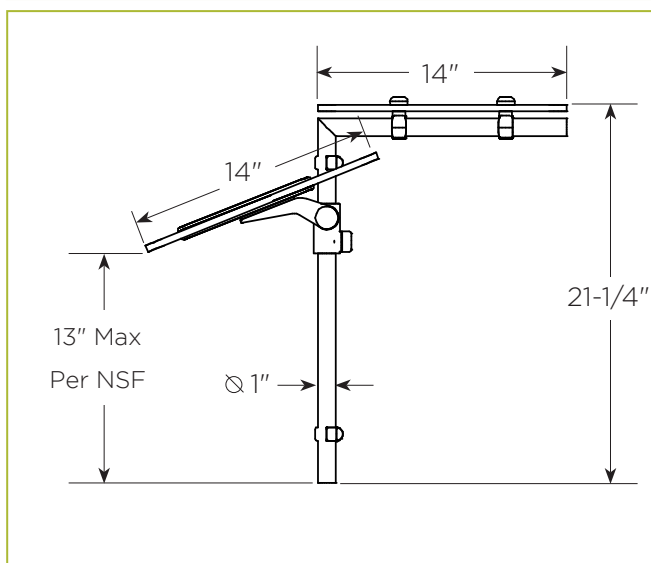
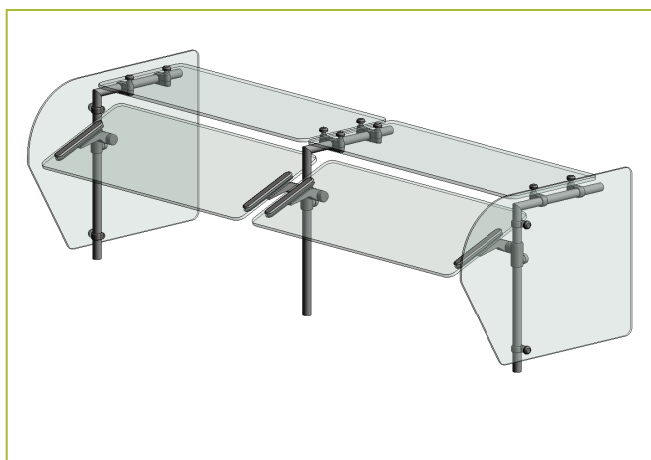

*To meet NSF guidelines, end panels are included on all BSI quotations unless specifically excluded. (See end panel page for more details.)*

Approval Drawings Required

Specifications subject to change without notice.

U.S. patent information is on file at BSI, LLC and available upon request.