

GENERAL INFORMATION

Project Name: _____

STANDARD FINISH

Brushed Aluminum

GLASS THICKNESS

1/4" Tempered Glass (not for shelves)
Centerline Max 54"

3/8" Tempered Glass (for shelf or span more than 54")
Centerline Max 66"

1/2" Tempered Glass (for shelf or span more than 66")
Centerline Max 72"

GLASS CORNERS

1" Radius Corner (standard)

Square Corners

LIGHT AND WARMER OPTIONS

LED Light Unit

Linear T-5 Fluorescent Unit

BSI Stealth™ Linear Heat Only Unit

BSI Stealth™ Linear Heat and Light Combo Unit
(Fluorescent)

BSI Stealth™ Linear Heat and Light Combo Unit (LED)

BSI Stealth™ Linear Double Heat and Light Combo Unit
(Fluorescent)

BSI Stealth™ Linear Double Heat and Light Combo Unit
(LED)

Hatco® Brand Heat Only Unit

Hatco® Brand Heat and Light Combo Unit

INSTALLATION OPTIONS

(See Installation Page for more details.)

Above-Counter: Stainless Steel Counter
SS1: EZ Mount 2" x 8" Flange

Under-Counter: Stainless Steel Counter*
SSU3-H: Heavy-Duty Flange (3-1/2" Dia.)

SSU3-N: Narrow Flange (1-1/4"x3")

SSU5-H: Heavy-Duty Flange (3-1/2" Dia.)

SSU5-N: Narrow Flange (1-1/4"x3")

* Requires Under-Counter Reinforcement and Access.

AG2930-3 Two-Tier Display Shelf

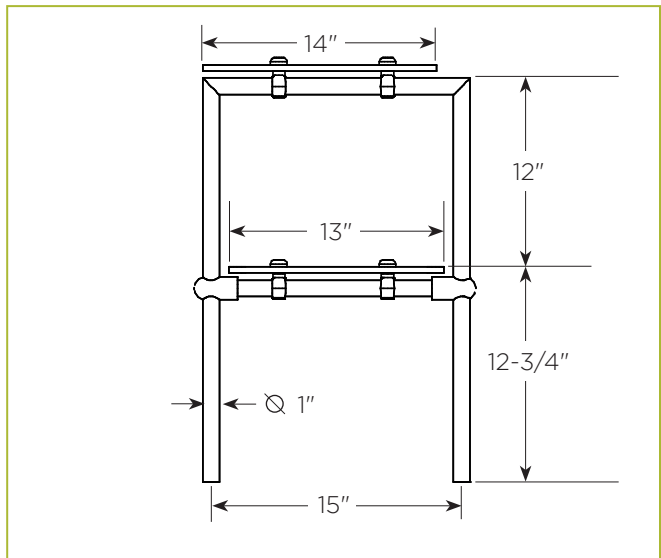
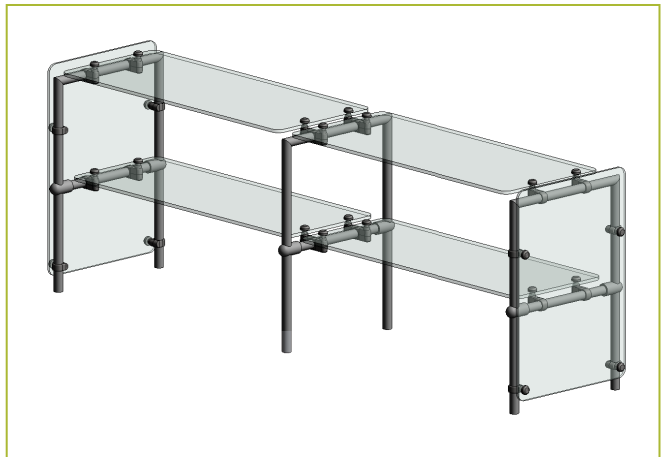

To meet NSF guidelines, end panels are included on all BSI quotations unless specifically excluded. (See end panel page for more details.)

To meet NSF guidelines the upper tier will be labeled "For prepackaged food only".

Above-Counter: Millwork Counter
MW1: Heavy-Duty Flange (3-1/2" Dia.)
MW2: Narrow Flange (1-1/4"x3")

Under-Counter: Millwork Counter
MWU4: Compression Installation
(not recommended for solid surfaces)
MWU5: Heavy-Duty Flange (3-1/2" Dia.)

Approval Drawings Required

Specifications subject to change without notice.

U.S. patent information is on file at BSI, LLC and available upon request.