

GENERAL INFORMATION

Project Name: _____

STANDARD FINISH

Brushed Aluminum

GLASS THICKNESS

1/4" Tempered Glass (not for shelves)
Centerline Max 54"

3/8" Tempered Glass (for shelf or span more than 54")
Centerline Max 66"

1/2" Tempered Glass (for shelf or span more than 66")
Centerline Max 72"

Maximum span between legs on counter is recommended at 78".

GLASS CORNERS

1" Radius Corner (standard)

Square Corners

LIGHT AND WARMER OPTIONS

LED Light Unit

Linear T-5 Fluorescent Unit

BSI Stealth™ Linear Heat Only Unit

BSI Stealth™ Linear Heat and Light Combo Unit
(Fluorescent)

BSI Stealth™ Linear Heat and Light Combo Unit (LED)

BSI Stealth™ Linear Double Heat and Light Combo Unit
(Fluorescent)

BSI Stealth™ Linear Double Heat and Light Combo Unit
(LED)

Hatco® Brand Heat Only Unit

Hatco® Brand Heat and Light Combo Unit

INSTALLATION OPTIONS

(See Installation Page for more details.)

Above-Counter

Surface Installation 720A/726A: Steel Post and Flange w/Flange Cover

Surface Installation 725A: Cut Flange

Under-Counter*

Under-Counter Installation 720A/726A: Steel Post and Flange w/Flange Cover or w/out Flange Cover

Under-Counter Installation 725A: Narrow Custom Flange

* Requires Under-Counter Reinforcement and Access.

AG2945-3

Double-Sided EZ Span

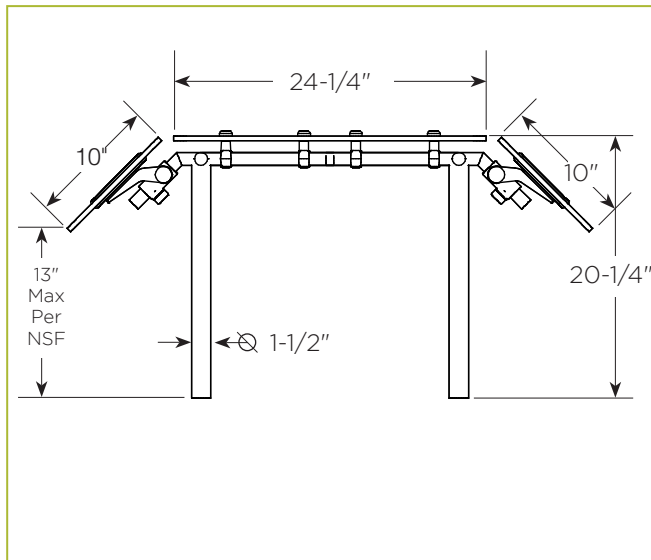
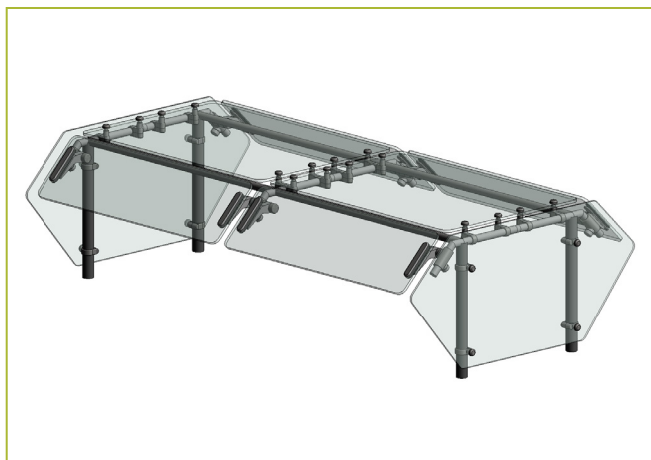

To meet NSF guidelines, end panels are included on all BSI quotations unless specifically excluded. (See end panel page for more details.)

Approval Drawings Required

Specifications subject to change without notice.

U.S. patent information is on file at BSI, LLC and available upon request.