

QUICK REFERENCE GUIDE

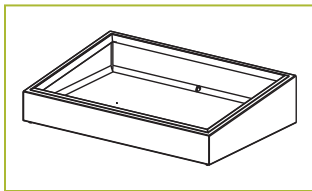

CP-120

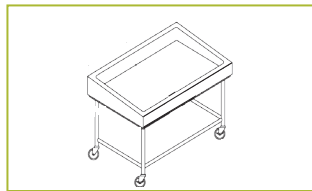

CP-480

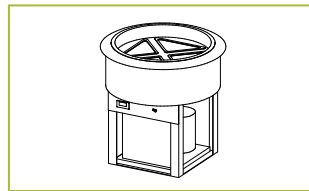

CP-500N

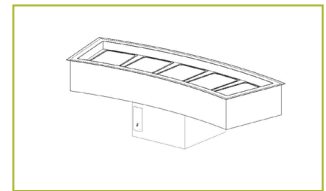

CP-600

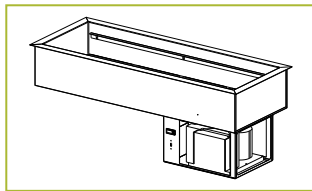

Custom Cold Pan

GENERAL INFORMATION

Project Name: _____
Item: _____
Quantity: _____
Model: CP-120 _____
Length: _____

GENERAL SPECIFICATION

Materials

- 18-Gauge Brushed Finish Type 304 Stainless Interior Pan Liner
- 16-Gauge Brushed Finish Type 304 Stainless Exterior
- Pressure Foamed Insulation
- 1/2" Drain with Ball Valve and 60" Clear PVC Drain Tube

Construction

- NSF Standard 2 Construction
- Coved Corner Pan

CP-120

Counter-Top Marche Style Cold Pan

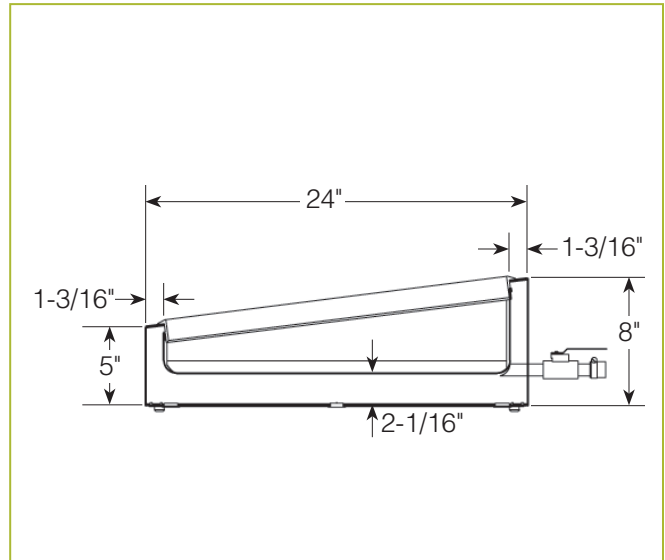

EXTERIOR MATERIAL OPTIONS

Hardwood Veneer: Type _____
 Hardwood (Solid): Type _____
 Plastic Laminate: Color _____
 Solid Surface: Color _____

EXTERIOR FINISH OPTIONS

Mirror Polished
 Stain: Type _____
 Powder Coat: Color _____

MODEL	CP-120-2424	CP-120-2430	CP-120-2436	CP-120-2442	CP-120-2448
Length	24"	30"	36"	42"	48"
Width	24"	24"	24"	24"	24"
Net Weight	40 lbs.	47 lbs.	55 lbs.	64 lbs.	73 lbs.
Shipping Weight	57 lbs.	63 lbs.	74 lbs.	85 lbs.	97 lbs.
Cubes	7	7	8	9	11

* Approval Drawings Required

Printed in the U.S.A. (January 2020) BSI, LLC
 Specifications subject to change without notice.

GENERAL INFORMATION

Project Name: _____
Item: _____
Quantity: _____
Model: CP-480 _____
Length: _____

GENERAL SPECIFICATION

Materials

- 18-Gauge Brushed Finish Type 304 Stainless Interior Pan Liner
- 16-Gauge Brushed Finish Type 304 Stainless Exterior
- Pressure Foamed Insulation
- 1/2" Drain with Ball Valve and 60" Clear PVC Drain Tube

Construction

- NSF Standard 2 Construction
- Coved Corner Pan

EXTERIOR MATERIAL OPTIONS

Hardwood Veneer: Type _____
 Hardwood (Solid): Type _____
 Plastic Laminate: Color _____
 Solid Surface: Color _____

EXTERIOR FINISH OPTIONS

Mirror Polished
 Stain: Type _____
 Powder Coat: Color _____
 Mechanical Refrigeration

CP-480

Mobile Marche Style Cold Pan

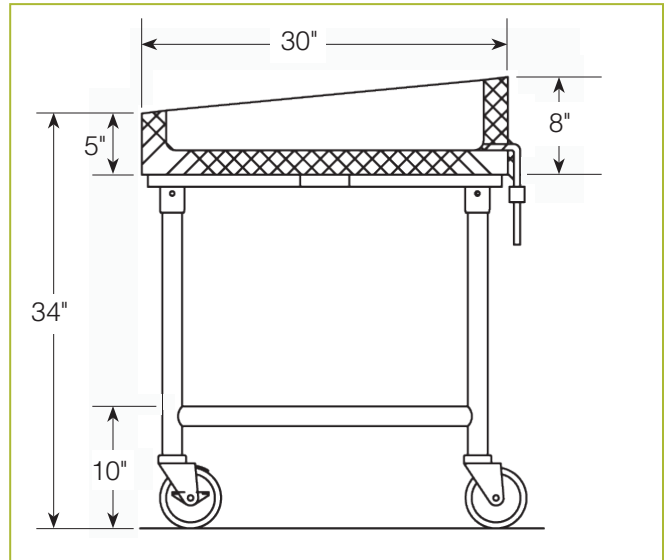
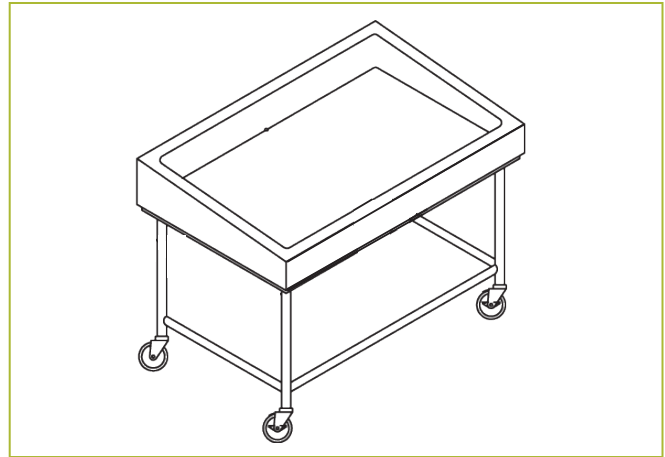

MODEL	CP-480-3036	CP-480-3048	CP-480-3060	CP-480-3072	CP-480-3084	CP-480-3636	CP-480-3648	CP-480-3660	CP-480-3672	CP-480-3684
Length	36"	48"	60"	72"	84"	36"	48"	60"	72"	84"
Width	30"	30"	30"	30"	30"	36"	36"	36"	36"	36"
Net Weight	125 lbs.	161 lbs.	198 lbs.	234 lbs.	270 lbs.	147 lbs.	189 lbs.	232 lbs.	274 lbs.	317 lbs.
Shipping Weight	175 lbs.	222 lbs.	270 lbs.	317 lbs.	365 lbs.	204 lbs.	258 lbs.	313 lbs.	368 lbs.	423 lbs.
Cubes	33	43	53	63	73	40	52	63	75	87

* Approval Drawings Required

Printed in the U.S.A. (January 2020) BSI, LLC
 Specifications subject to change without notice.

GENERAL INFORMATION

Project Name: _____
Item: _____
Quantity: _____
Model: CP-500N
Length: _____

The CP-500N is manufactured by BSI, LLC. The refrigerated rotating cold pan offers a unique approach in holding and displaying food items. It's round, multi-bin form factor allows multiple food offerings from a compact space. By spinning the outer ring of the unit the customer can quickly rotate it to allow access to the food bin of their choice.

The CP-500N is available as a part of a larger counter unit or a self-contained mobile unit.

GENERAL SPECIFICATION

Materials

- 14 Gauge #4 Brushed Finish Type 304 Stainless Interior Pan Liner and Top Flange
- 18 Gauge Galvanized Exterior Pan Liner
- 14 Gauge Galvanized Condensing Unit Housing
- 1-1/2" Thick Standard Foam in Place Insulation

Construction

- NSF Standard 7 Construction Refrigerators and Freezers
 - CP-500N pans are 3" below counter for cold air to circulate over the food
- R404a Refrigerant

Standard Size

- 9" Unit Depth with 6" Pans
- Diameter: 24", 30", or 36" (inside tub dimension)

UNIT DIAMETER

- 24" with 6 Bain Mariers or 4 Triangular Pans
- 30" with 12 Bain Mariers or 4 Triangular Pans
- 36" with 18 Bain Mariers or 4 Triangular Pans

PAN OPTIONS

- Standard Bain Marie (4-3/8" Diameter)
- Standard 6" Triangular Pan (Qty. 4)

Custom pan sizes and configurations are available. Contact BSI for more information.



* Approval Drawings Required

Printed in the U.S.A. (January 2020 BSI, LLC
Specifications subject to change without notice.)

CP-500N

Drop-in Rotating Cold Pan

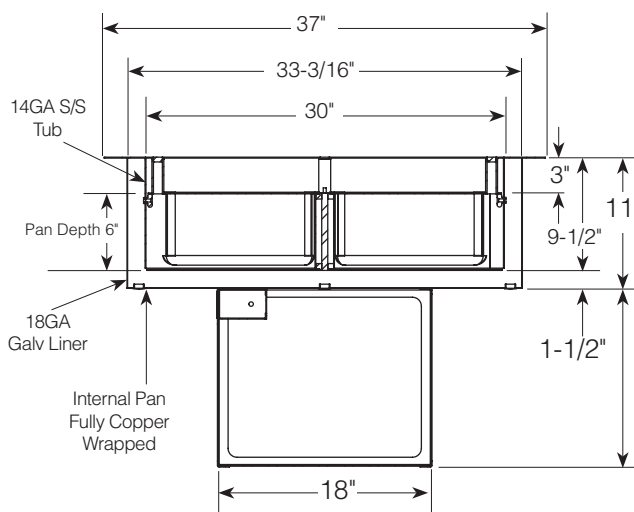

REFRIGERATION UNIT OPTIONS

- Self-Contained (Standard)
- Remote
 - Less condensing unit
 - Unit includes refrigerated cold pan, digital thermostat, expansion valve and solenoid valve.

ACCESSORIES

- Remote Control Panel for Counter Mounting
- Food Shield (Contact BSI for more information.)

MODEL	CP-500N-24	CP-500N-30	CP-500N-36
Compressor	1/4 Hp	1/4 Hp	1/4 Hp
Refrigerant	R404a	R404a	R404a
Volts	120	120	120
Amps	6.7	6.7	6.7
BTU's	500	700	1000
Plug	NEMA 5-15	NEMA 5-15	NEMA 5-15

GENERAL INFORMATION

Project Name: _____
Item: _____
Quantity: _____
Model: CP-600
Length: _____

DESCRIPTION

The Custom Mechanical Drop-In, Curved Cold pan is manufactured by BSI, LLC. The maximum size is 6' on the outside radius.

For larger sizes contact the factory at 1.800.662.9595.

GENERAL SPECIFICATION

Materials

- 14-Gauge Brushed Finish Type 304 Stainless Interior
- 18-Gauge Brushed Finish Type 304 Stainless Exterior Below Cabinet
- 2" Pressure Foamed Installation
- 1/2" Drain with Ball Valve

Construction

- BSI builds to NSF Standard 7 Construction
- 404 Refrigerant

Standard Size

- 10" Unit Depth
- 2-1/2" Flange on both sides

REFRIGERATION UNIT OPTIONS

- Self-Contained (Standard)
- Remote

PAN OPTIONS

- Perforated Pans

CP-600

Custom Mechanical Drop-In, Curved Cold Pan

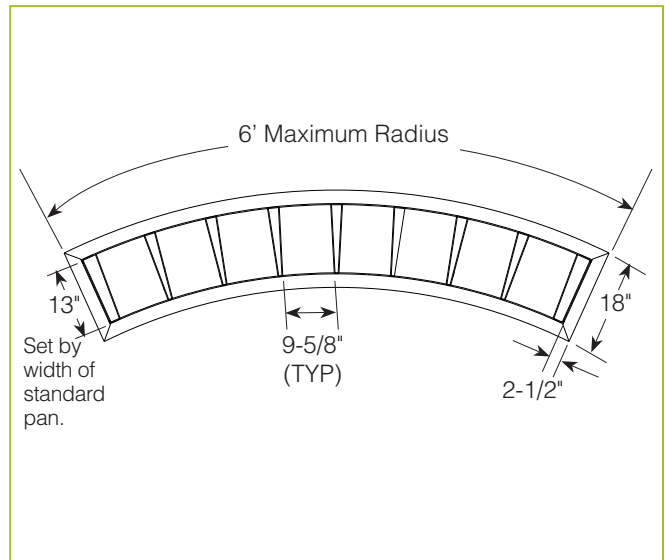
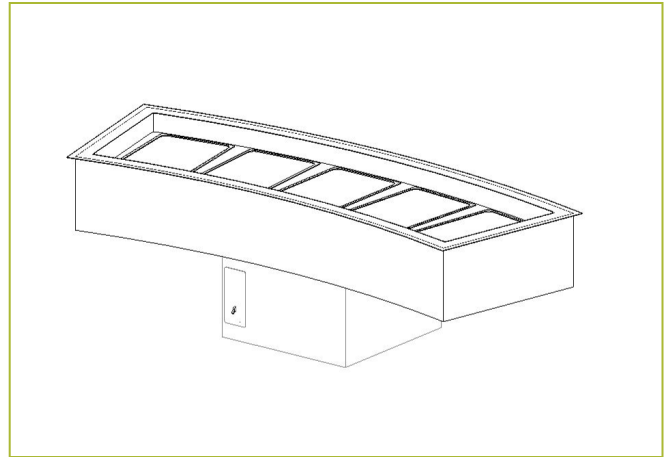

* Approval Drawings Required

Printed in the U.S.A. (January 2020) BSI, LLC
 Specifications subject to change without notice.

GENERAL INFORMATION

Project Name: _____
 Item: _____
 Quantity: _____
 Model: _____
 Length: _____

DESCRIPTION

The Custom Mechanical Drop-In Cold pan is manufactured by BSI, LLC.

Standard size shown. For custom sizes contact the factory at 1.800.662.9595.

GENERAL SPECIFICATION

Materials

- 14-Gauge Brushed Finish Type 304 Stainless Interior
- 18-Gauge Brushed Finish Type 304 Stainless Exterior Below Cabinet
- 2" Pressure Foamed Installation
- 1/2" Drain with Ball Valve

Construction

- BSI builds to NSF Standard 7 Construction
- 404 Refrigerant

Standard Size

- 10" Unit Depth
- 2-1/2" Flange on both sides
- Inside Rectangle - 22" W x 38-1/2" L
- Full Rectangle - 27" W x 43-1/2" L

REFRIGERATION UNIT OPTIONS

- Self-Contained (Standard)
- Remote

PAN OPTIONS

- Perforated Pans

CUSTOM COLD PAN

Custom Mechanical Drop-In Cold Pan

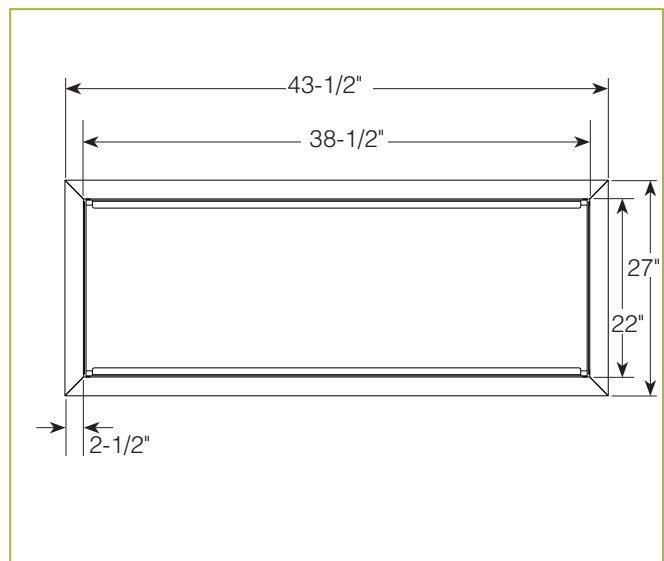
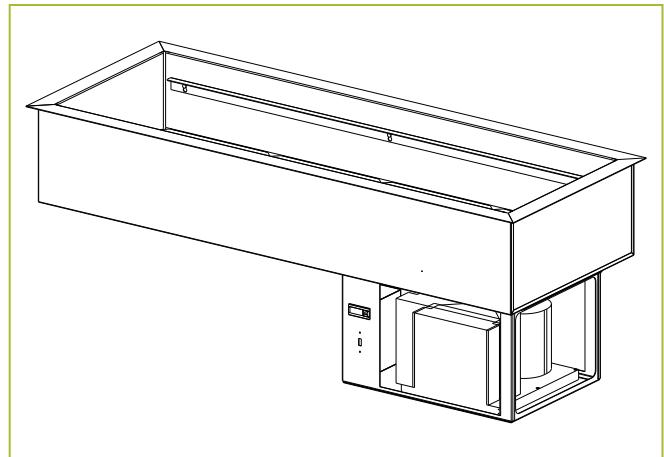

* Approval Drawings Required

Printed in the U.S.A. (January 2020) BSI, LLC
 Specifications subject to change without notice.