

GENERAL INFORMATION

Project Name: _____
 Item: _____
 Quantity: _____
 Model: _____ DECO-953
 Length: _____

STANDARD NSF LISTED FINISH OPTIONS

- Stainless Steel #4
- Chrome
- Gloss Black
- Wrinkle Black
- Smoked Copper
- Polished Brass Finish
- Other _____

LIGHT AND WARMER OPTIONS

- LED Light Unit
- Linear T-5 Fluorescent Unit
- BSI Stealth™ Linear Heat Only Unit
- BSI Stealth™ Linear Heat and Light Combo Unit (Fluorescent)
- BSI Stealth™ Linear Heat and Light Combo Unit (LED)
- BSI Stealth™ Linear Double Heat and Light Combo Unit (Fluorescent)
- BSI Stealth™ Linear Double Heat and Light Combo Unit (LED)
- Hatco® Brand Heat Only Unit
- Hatco® Brand Heat and Light Combo Unit

GLASS THICKNESS

- 1/4" Tempered Glass (not for shelves)
Centerline Max 54"
- 3/8" Tempered Glass (for shelf or span more than 54")
Centerline Max 66"
- 1/2" Tempered Glass (for shelf or span more than 66")
Centerline Max 72"

GLASS CORNERS

- 1" Radius Corner (standard)
- Square Corners

INSTALLATION OPTIONS

Above-Counter: Stainless Steel Counter
Under-Counter: Stainless Steel Counter
 (Requires Under-Counter Reinforcement & Access)

Above-Counter: Millwork Counter
Under-Counter: Millwork Counter

- DECO Above-Counter Flange
- SSU3-H: Heavy-Duty Flange
- SSU3-N: Narrow Flange
- SSU5-H: Heavy-Duty Flange
- SSU5-N: Narrow Flange
- DECO Above-Counter Flange
- MWU3: Narrow Flange
- MWU4: Compression Installation (not recommended for solid surfaces)
- MWU5: Heavy-Duty Flange

See Installation Page for More Details.

DECO-953

Single-Sided w/Top Shelf



Shown without end panels.

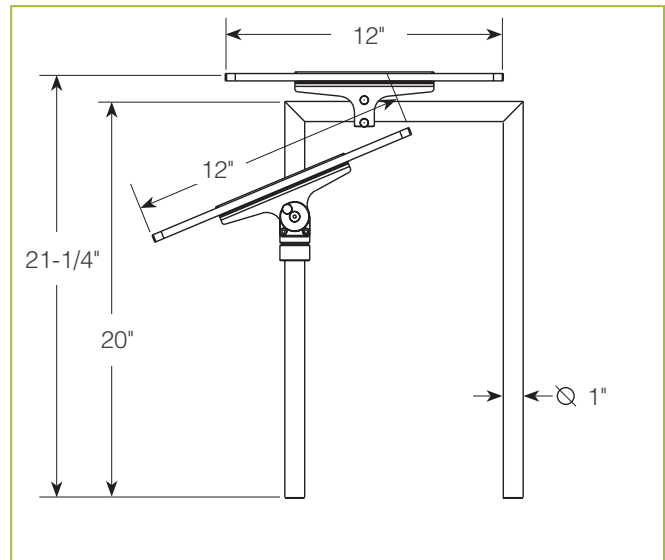

To meet NSF guidelines, end panels are included on all BSI quotations unless specifically excluded. (See End Panel Page for More Details.)

* Approval Drawings Required

Specifications subject to change without notice.