



# **OWNER'S MANUAL & WARRANTY**

---

## **DECO ENGINEERED FOOD SHIELDS**

### **LIGHTS & WARMERS**

Important Owner Information .....	2	<i>LIGHTS &amp; WARMERS</i>	1
Safety Precautions .....	3	Receiving & Inspecting the Equipment.....	10
Receiving and Inspecting the Equipment .....	3	Models.....	10
		Cleaning Instructions.....	11
<i>DECO Engineered Food Shields</i>		Identifying Your Product.....	11
Models .....	3-5	Changing the LED Bulb.....	11
Cleaning Instructions.....	6	Heating Elements.....	12
Glass Limitations & Testing.....	6	Parts & Service.....	12
Above-Counter Installation Options.....	7	Wiring Installations.....	13
Under-Counter Installation Options.....	8	Wiring Diagrams.....	14
		Warranty.....	15

The BSI, LLC manual is an important part of your equipment. This document should be stored in a safe location, as it will be useful for the life of your product. It contains important safety information concerning the maintenance, operation and servicing of these products.

Failure to properly use this manual may result in serious injury. Do not operate this equipment unless you have read and understood the contents of this manual.

## IMPORTANT OWNER INFORMATION

Record the model number(s) of your DECO food shield and serial number(s), of your warming units to use as a reference when contacting your local representative or the BSI headquarters in Colorado.

Model No.:	
Serial No.:	
Model No.:	
Serial No.:	
Date of Purchase:	
Other:	

BSI, LLC  
 Business Hours: 8:00 a.m. to 4:30 p.m.  
 Mountain Time

Telephone: (800) 662-9595; (303) 331-8777  
 Fax: (303) 331-8444

Web Address: [www.BSIdesigns.com](http://www.BSIdesigns.com)

## SAFETY PRECAUTIONS



The DECO Engineered Series Food Shield must be installed in accordance with the applicable installation code by a person familiar with the construction and operation of the product and the hazards involved.

## RECEIVING AND INSPECTING THE EQUIPMENT

Even though most equipment is shipped crated, care should be taken during unloading so the equipment is not damaged while being moved into your facility.

1. Visually inspect the exterior of the package and skid or container. Any damage should be noted and reported to the delivering carrier immediately.
2. If damaged, open and inspect the contents with the carrier.
3. In the event that the exterior is not damaged, yet, upon opening, there is concealed damage to the equipment, notify the carrier. Notification should be made verbally as well as in written form.
4. Request an inspection by the shipping company of the damaged equipment. This should be done within 10 days from receipt of the equipment.
5. Be sure to check that there is no broken glass.
6. Be sure to check that all materials are received.
7. Freight carriers can supply the necessary damage forms upon request.
8. Retain all crating materials until an inspection has been made or waived.
9. All DECO packages contain drawings for your installer.
10. All DECO packages contain this Owner's Manual and Warranty.

## DECO ENGINEERED SERIES MODELS

DECO Engineered Series food shields are manufactured in many different configurations. While the components are all similar, your model's glass may not be. Glass thickness may be different. The models shown below should be maintained in the same manner based on the instructions within this manual.

If you have questions regarding a DECO model not listed please contact BSI, LLC at 1.800.662.8777.



DECO-100-N



DECO-101-N



DECO-104-N



DECO-106-N



DECO-102-N



DECO-103-N



DECO-108-N



DECO-109-N

All DECO models are certified by NSF.



## MODELS



DECO-200-N



DECO-202-N



DECO-203-N



DECO-205-N



DECO-250-N



DECO-253-N



DECO-254-N



DECO-257-N



DECO-258-N



DECO-259-N



DECO-260-N



DECO-265-N



DECO-267-N



DECO-270-N



DECO-271-N



DECO-280-N



DECO-301-N



DECO-302-N



DECO-303-N



DECO-320-N



DECO-331-N



DECO-332-N



DECO-333-N



DECO-334-N

## MODELS



DECO-335-N



DECO-336-N



DECO-337-N



DECO-400-N



DECO-420-N



DECO-800-N



DECO-802-N



DECO-803-N



DECO-804-N



DECO-820-N

DECO Engineered food shields are manufactured in many different configurations. While the components are all similar, your model's glass and posts may not be. The models shown should be maintained in the same manner based on the instructions within this manual.

If you have questions regarding a DECO Engineered food shields or are interested in custom configurations please contact BSI, LLC at 1.800.662.8777.

## CLEANING INSTRUCTIONS

Preserving the cleanliness of your new BSI product is key to its long life.

BSI recommends the following for keeping your product clean:

- Wipe the surface with a clean, damp cloth to remove fingerprints, dust, etc.
- Spray with a light coating of glass cleaner to remove grease or other dirt. Use a non-ammonia cleaner.
- Do not polish the stainless steel with any brass polish. Your food shield has a durable finish and will maintain its finish for years if well maintained. (Polishing the finish with a polishing agent of any kind will destroy the coating.)
- Do not scrub the surface with any abrasive substance such as steel wool, pot scrubbers, Ajax cleanser, Comet or similar products, as it will remove the protective coating.

---

## GLASS LIMITATIONS



BSI food shield systems that are equipped with a shelf are not intended to withstand heavy weights. Glass shelves can certainly hold small display items.

## RECOMMENDATIONS

Do not exceed **75lbs.** total weight of all display items across a three-foot panel of 3/8" thick glass.

## ABOVE-COUNTER INSTALLATION FOR DECO ENGINEERED POSTS - NARROW FLANGE

1-1/2" Narrow Flange

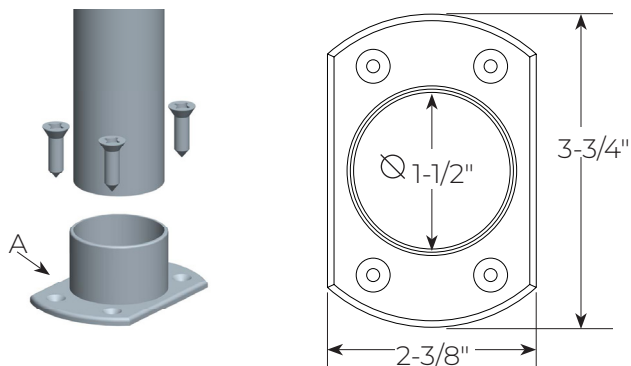

## ABOVE-COUNTER INSTALLATION FOR DECO ENGINEERED POSTS - ROUND FLANGE

1" Round Flange

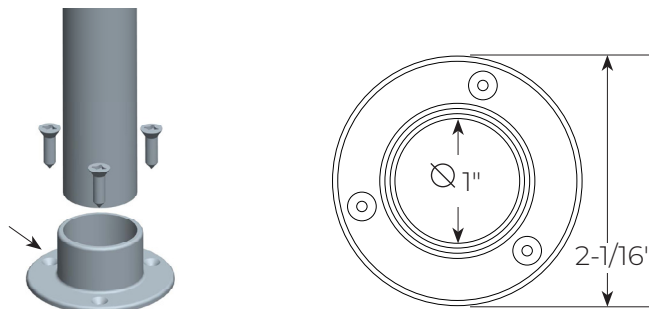

1-1/2" Round Flange

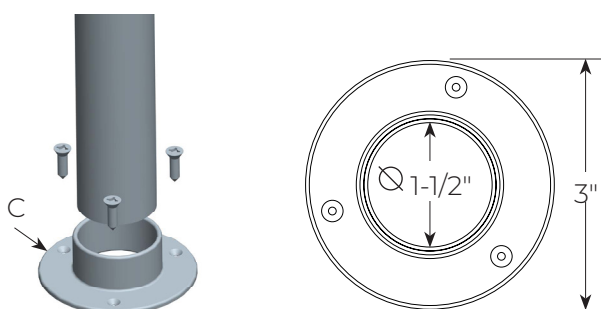

## ABOVE-COUNTER INSTALLATION FOR DECO ENGINEERED POSTS - RECTANGULAR/SQUARE FLANGE

Rectangular Flange

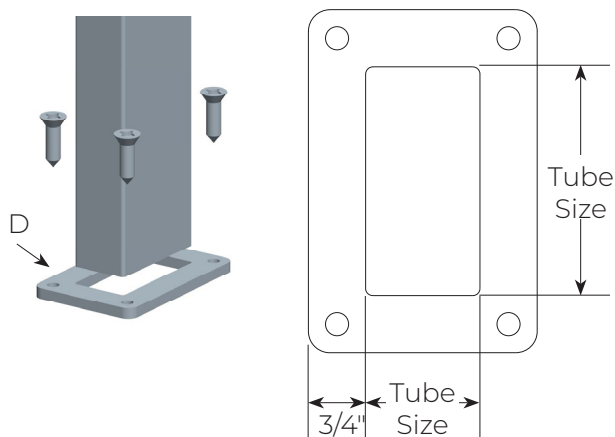

Square Flange

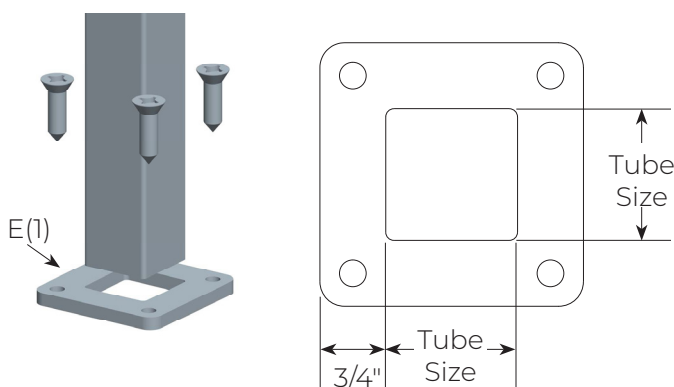

Location	Part #	Part Name
A	10652APS	1-1/2" Diameter Narrow Flange

Location	Part #	Part Name
D	15987	1" x 2" Rectangle Flange
E	611	1" Square Flange
E1	16006	1-1/2" Square Flange

## UNDER-COUNTER INSTALLATION FOR DECO ENGINEERED FOR ROUND POSTS (requires under-counter reinforcement and access)

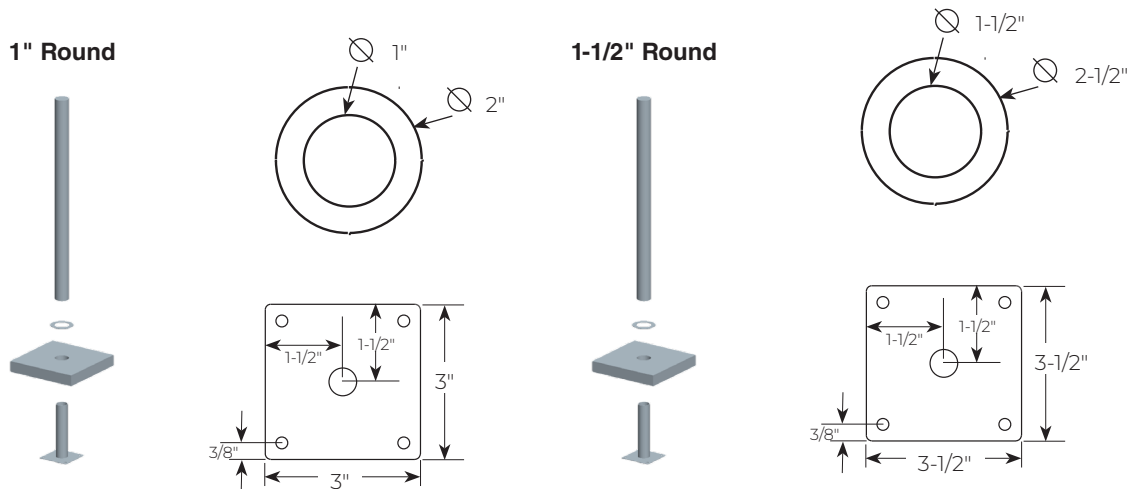

## UNDER-COUNTER INSTALLATION FOR RECTANGLE POSTS (requires under-counter reinforcement and access)

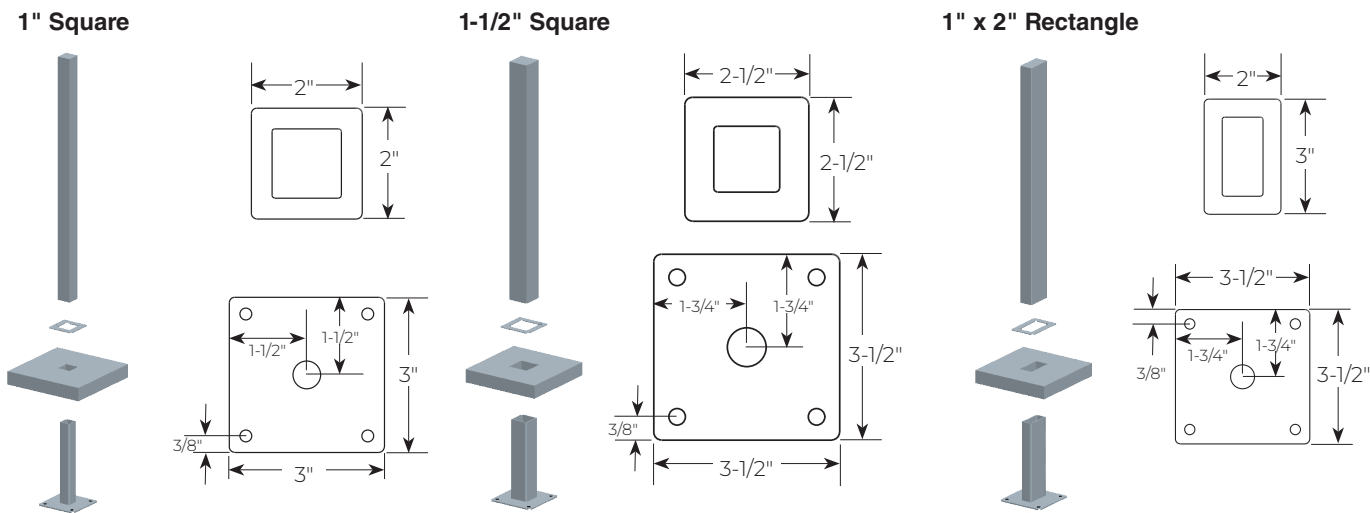





# **OWNER'S MANUAL & WARRANTY**

---

## **LIGHTS & WARMERS**

## LIGHTS & WARMERS

Food shield systems can be built with lights, warmers, or a combination of the two. Proper maintenance for these products is very important for safety. The following pages will detail the proper methods of keeping your product clean, how and where to exchange parts, and includes diagrams for proper wiring.

## RECEIVING AND INSPECTING THE EQUIPMENT

Care should be taken during unloading and uncrating to avoid equipment damage.

1. Visually inspect the package, skid, or container exterior. Any damage should be noted and reported to the delivering carrier immediately.
2. Open and inspect contents for broken glass and verify that all items were received.
3. In the event that damage is discovered, notify the carrier and request freight damage forms.
4. Request an inspection by the shipping company of the damaged equipment. This should be done within 10 days of equipment receipt.
5. Retain all crating materials until an inspection has been made or waived.



*ALL LIGHTS, WARMERS AND COMBO UNITS ARE SHIPPED USING ZIP TIES TO SECURE UNITS DURING TRANSIT. AFTER INSTALLATION, CAREFULLY REMOVE ALL ZIP TIES.*



Lights and warmers must be installed in accordance with the applicable installation code by a person familiar with the product's construction, operation, and potential hazards involved.

All light and warmer models are certified by NSF.



## MODELS



Stealth Warmer & Light Combo Model 705  
Stealth Warmer Model 790

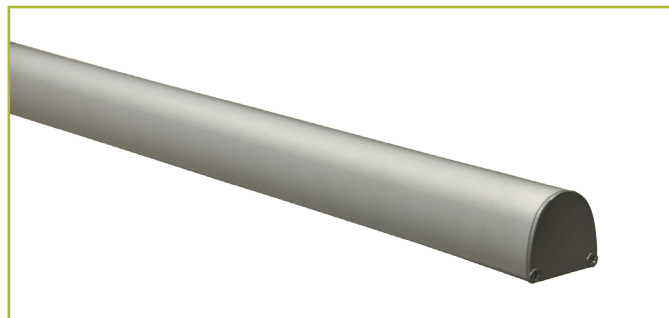

Slimline Light Model 2580

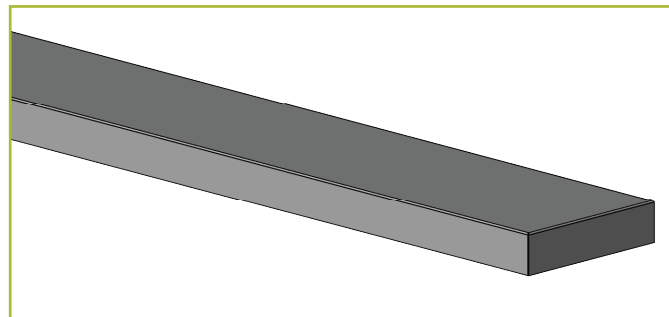

Stealth Heat/Light/Heat Combo Model 500

## CLEANING INSTRUCTIONS

Once your food guard has been properly installed and you have removed all zip ties, it will be important to keep your light, warmer, or combo unit clean to prolong the life of the product.

BSI recommends the following for keeping your product clean:

- Be sure to turn the power off before cleaning. Wait until Stealth warmer is cool. **Cleaning when the warmer is hot can cause staining or damage to food warmer finish.**
- Wipe the surface with a clean, damp cloth to remove fingerprints, dust, etc.
- Spray with a light coating of glass cleaner to remove grease or other dirt. Use a non-ammonia cleaner.
- Be sure not to spray any cleaning product directly into the bulbs, fixtures, or heating elements.

## IDENTIFYING YOUR PRODUCT

Each BSI light, warmer, or combo unit contains an identification sticker. This sticker provides the customer with the following information:

- Serial Number
- Model Number
- Manufacture Date
- Electrical Information



## CHANGING THE LED BULB

- Turn off power to all lights and warmers.
- Carefully unscrew the end plate and slide out the entire LED light.
- If multiple lights are connected to each other, carefully disconnect serial connector or power connector.
- Once dead light bulb is removed, replace with new LED light. Carefully reconnect the connector and slide in the light bar.
- Replace end cover and two screws.

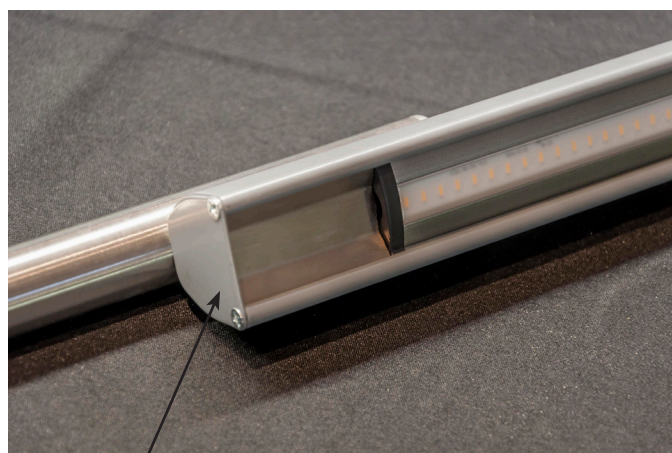

End Plate

## LED LIGHTS

Part #	Description
16289	Kelly LED:_12" _LED_Light_Bar
16290	Kelly LED:_18" _LED_Light_Bar
16292	Kelly LED:_36" _LED_Light_Bar
16505	Kelly LED:_48" _LED_Light_Bar
16293	Kelly LED:_10' _Power_Cord_w/o_Plug
16294	Kelly LED:_Serial_Connector
16295	Kelly LED:_6" Power_Connector

## HEATING ELEMENTS

Part #	Description
492-18-BK	Element:_18"_120V_Heater_350W
492-24-BK	Element:_24"_120V_Heater_500W
492-30-BK	Element:_30"_120V_Heater_660W
492-36-BK	Element:_36"_120V_Heater_800W
492-42-BK	Element:_42"_120V_Heater_950W
492-48-BK	Element:_48"_120V_Heater_1100W
492-54-BK	Element:_54"_120V_Heater_1250W
492-60-BK	Element:_60"_120V_Heater_1400W
492-66-BK	Element:_66"_120V_Heater_1560W

Part #	Description
496-24-BK	Element:_24"_208V_Heater_500W
496-30-BK	Element:_30"_208V_Heater_660W
496-36-BK	Element:_36"_208V_Heater_800W
496-42-BK	Element:_42"_208V_Heater_950W
496-48-BK	Element:_48"_208V_Heater_1100W
496-54-BK	Element:_54"_208V_Heater_1250W
496-60-BK	Element:_60"_208V_Heater_1400W
496-66-BK	Element:_66"_208V_Heater_1560W

240V Heat Elements are a special order item. Contact BSI at 1.800.662.9595 to order.

### REPLACING THE TUBULAR HEATING ELEMENTS

On all three Stealth warmer units, the tubular heating element can burn out — similar to a light bulb.

Replacement should be done by a professional service technician. If you have additional questions, contact BSI at 1.800.662.9595.

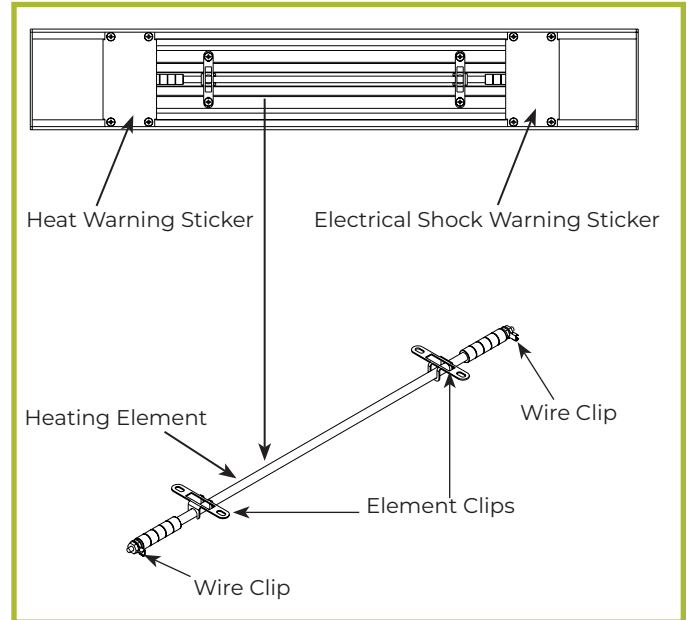

## PARTS & SERVICE

In the event your lights or warmers require major repairs, contact your local installer for assistance.

If you have product questions or need minor replacement parts, contact BSI at 1.800.662.9595.

## WIRING INSTALLATIONS

### Slimline 2580 LED Light

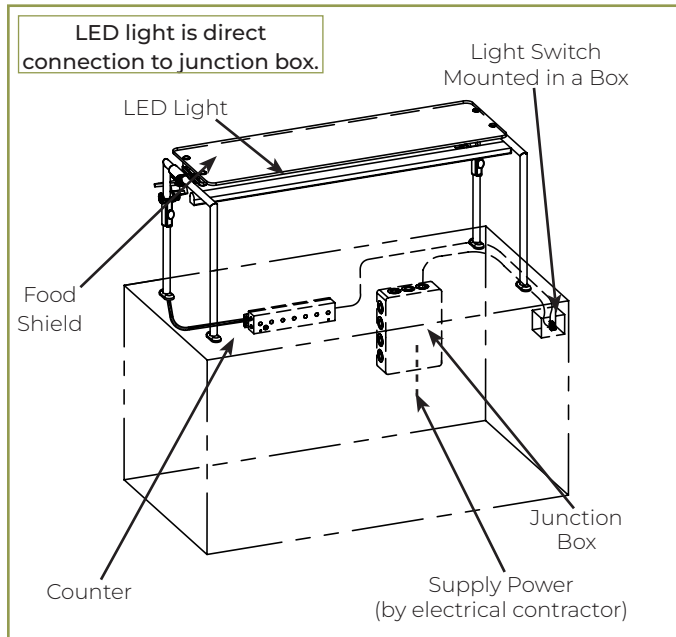

### Stealth 790 Warmer

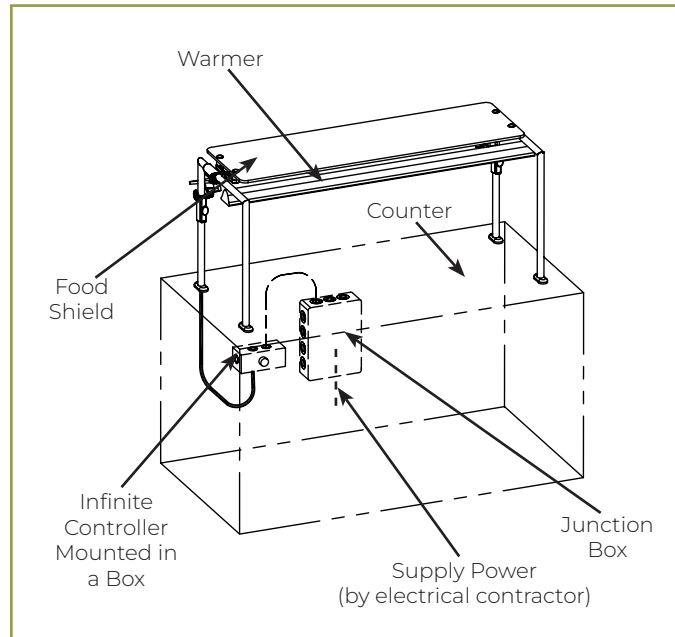

### Stealth 705 LED Light & Warmer Combo

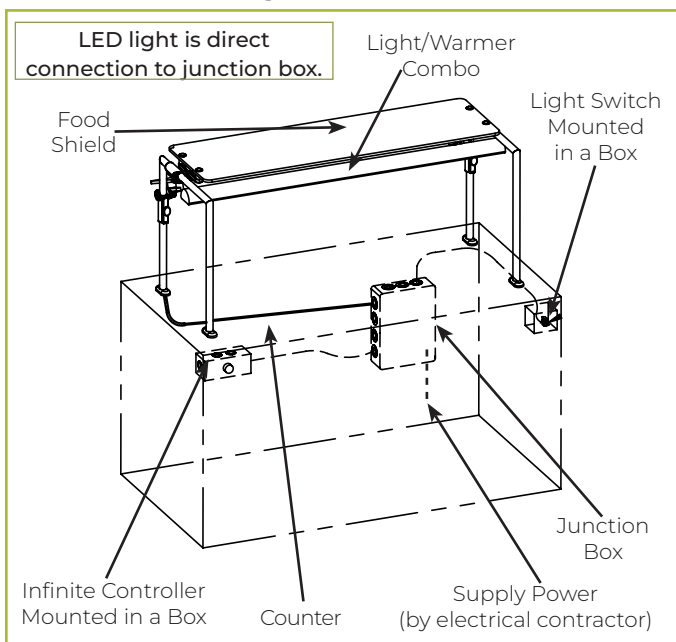

### Stealth 500 LED Heat/Light/Heat Combo

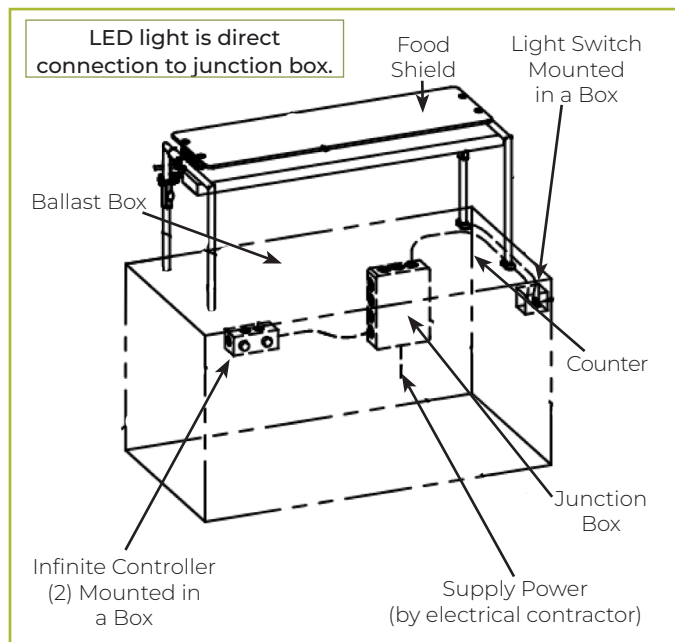

## INSTALLATION INFORMATION

- All wiring should be performed by a certified technician.
- Wires are routed through wire chase/support legs per approved shop drawings.
- Mount the infinite controllers near the wire chase/support leg.
- The infinite controllers, light switch, and six feet of conduit/wiring exiting support legs are provided with all BSI lights & warmers.

# WIRING DIAGRAMS

## Remote Infinite Control for Stealth Warmer/Combo Units

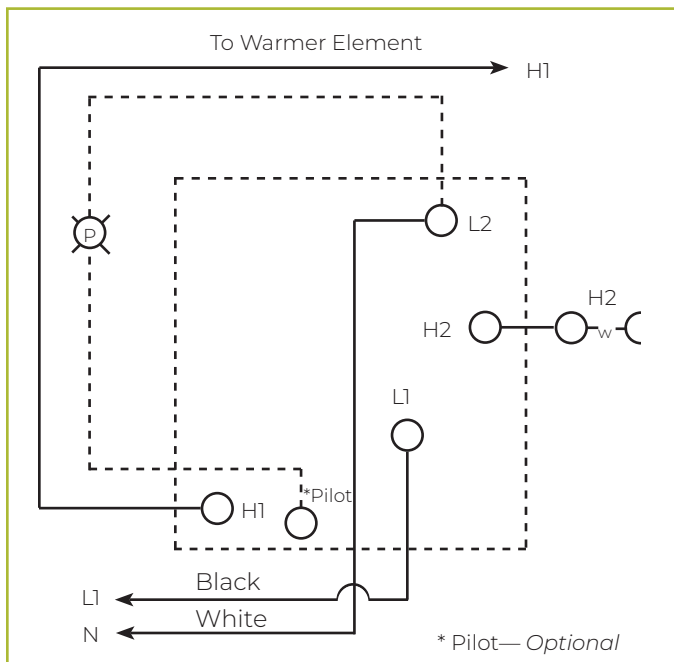

Infinite Switch (120V) - Part #581

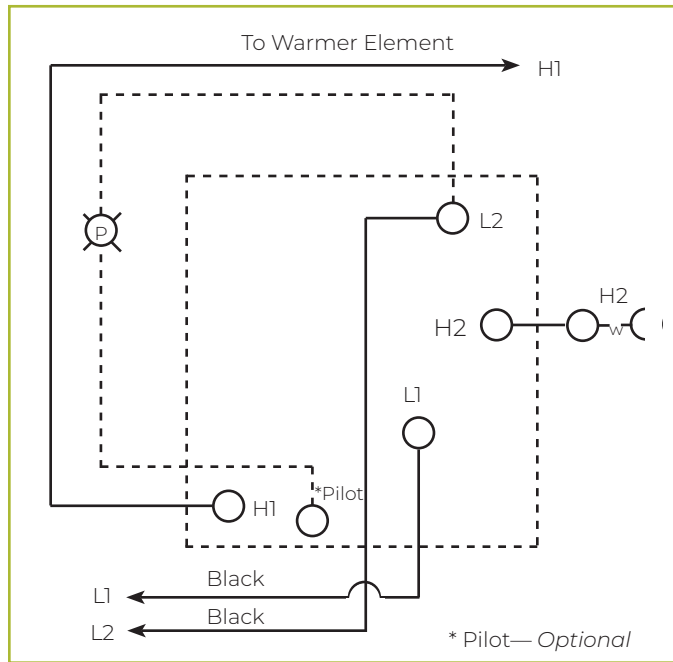

Infinite Switch (208V/240V) - Part #582

## **BSI, LLC WARRANTY**

BSI, LLC warrants its products to be free of material and workmanship defects under normal use from the date of original purchase and for the applicable warranty periods set forth below. BSI, LLC's warranty extends only to original purchasers acquiring new products purchased in the United States directly from BSI, LLC, its authorized dealers, or other companies specifically authorized by BSI, LLC to act as resellers of its products.

### **DECO ENGINEERED FOOD GUARDS**

BSI, LLC warrants the DECO Engineered guards against material and workmanship defects for a period of two years from invoice date. This excludes post-installation glass chipping or breakage that can be explained as "standard wear and tear."

### **STEALTH WARMERS**

BSI, LLC warrants the Stealth housing and warming element against material and workmanship defects for a period of two years from invoice date.

### **SLIMLINE LED LIGHT**

The Slimline LED light warranty covers the ballast for material and workmanship for a period of two years from invoice date. The LED bulb itself is not covered under warranty.

THERE ARE NO WARRANTIES EXCEPT AS STATED ABOVE, WHETHER EXPRESSED OR IMPLIED, INCLUDING, BUT NOT LIMITED TO, ANY WARRANTY OF MERCHANTABILITY OR FITNESS FOR A PARTICULAR PURPOSE. Warranties do not apply to products that have been altered in any way or to products subjected to misuse, abuse, neglect, accident, or damage in transit. Warranty is void if products are used, held, or stored in an unsupervised environment. BSI, LLC's liability shall be limited to product repair or replacement, or refund of purchase price issued at the discretion of BSI, LLC. BSI, LLC will not be liable, under any circumstances, for incidental or consequential damages (including, without limitation, to lost profits) arising in connection with the sale, use, inability to use, repair, or replacement of BSI, LLC's products. The liability of BSI, LLC arising from any cause shall not exceed the price paid for the products.

Any breach claim of the foregoing warranties shall be deemed waived unless submitted to BSI, LLC in writing within 30 days of alleged defect discovery date or by reasonable inspection should have been discovered. Merchandise must be returned to the BSI, LLC factory, freight prepaid, and will not be accepted unless a prior Return Merchandise Authorization (RMA) has been issued by BSI, LLC. A copy of the original invoice must accompany the returned merchandise to verify the original purchase date and warranty entitlement. Any cause of action for breach of the foregoing warranties shall be deemed waived unless brought within one year of claim submission.