

GENERAL INFORMATION

Project Name: _____
 Item: _____
 Quantity: _____
 Model: _____ FTS
 Length: _____

GENERAL SPECIFICATION

Materials

- 14-Gauge Brushed Finish Type 304 Stainless
- 6" Diameter Box Pattern Stainless Drain
- Removable Perforated Stainless Basket
- 1/8" x 1" Type 304 Stainless Subway Grate with 3/8" Stainless Reinforcement Rods (minimum of 2)

Construction

- NSF Standard 2 Construction
- Coved Corner Pan
- True Positive Pitch Toward Drain
- 3-15/16" I.D. 6" Long Stainless Tailpiece
- Maximum Gap Between Grate Bars of 13/16"
- Maximum Space Between Reinforcement Rods of 6"

TROUGH MATERIAL OPTIONS

- 12-Gauge Brushed Finish Stainless
- Type 316 Stainless

TROUGH FINISH OPTIONS

- Sand Blast
- Mirror Polished

GRATE TYPE OPTIONS

- 3/16" x 1" Stainless Subway Grate
- 1/4" x 1" Stainless Subway Grate
- Anti-Slip Fiberglass Grating
- Custom Bar Centerlines: Dimensions _____
- Type 316 Stainless

MODELS AND DIMENSIONS

Sizes WxL	24"	36"	48"	60"	72"	84"	96"	108"	120"
12"	FTS-1224	FTS-1236	FTS-1248	FTS-1260	FTS-1270	FTS-1284	FTS-1296	FTS-12108	FTS-12120
18"	FTS-1824	FTS-1836	FTS-1848	FTS-1860	FTS-1872	FTS-1884	FTS-1884	FTS-18108	FTS-18120
24"	FTS-2424	FTS-2436	FTS-2448	FTS-2460	FTS-2472	FTS-2484	FTS-2484	FTS-24108	FTS-24120
30"	FTS-3024	FTS-3036	FTS-3048	FTS-3060	FTS-3072	FTS-3084	FTS-3084	FTS-30108	FTS-30120

* Approval Drawings Required

Specifications subject to change without notice.

FTS

Shallow Floor Trough

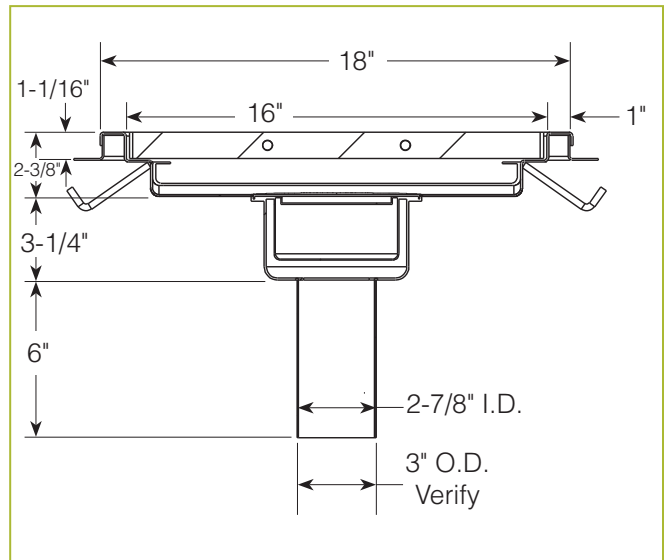

OTHER OPTIONS

- Off-Center Drain
- Extended Drain Pan Without Grate (see model FTDP)
- 1/4" Stainless Rod J-Anchors Around Trough Exterior