

**GENERAL INFORMATION**

**Project Name:** \_\_\_\_\_  
**Item:** \_\_\_\_\_  
**Quantity:** \_\_\_\_\_  
**Model:** CUSTOM BEER CART  
**Length:** \_\_\_\_\_

**STANDARD FEATURES**

- 16 gauge #304 stainless steel countertop
- 18 gauge #304 stainless steel trim
- 6" casters, two (2) rigid and two (2) swivel with brakes
- Black rubber caster skirt on three (3) sides
- Powder coated exterior panels (red, blue or yellow)
- Open keg storage compartment
- Stainless steel drip trough
- Stainless steel ice bin with lid and cold plate
- Stainless steel round retractable awning poles
- A-Frame awning with fabric covering (red, blue or yellow)
- Beer Tower - dual faucet
- 4 - Product cold plate (inside ice bin)
- All tanks, valves, piping and fittings to comply with all NSF, local, state and federal health codes and standards
- U.L. Listed
- NSF Listed to Standard 59

**OPTIONS**

- Removable stainless steel cup shelf
- Metal cash drawer
- Vinyl bumper
- Square awning poles
- Fixed awning poles
- Drop shelf
- Round awning
- Custom exterior panels (laminated, stainless steel, powder coat, etc.)
- Custom colors
- Custom graphics
- Menu board
- Track lights
- Cart cover
- Portable waste tank

**ELECTRICAL REQUIREMENTS**

- 120 Volt / 1 Phase / 20 Amp

Specifications subject to change without notice.

**CUSTOM BEER CART**  
4 Keg Draft Beer

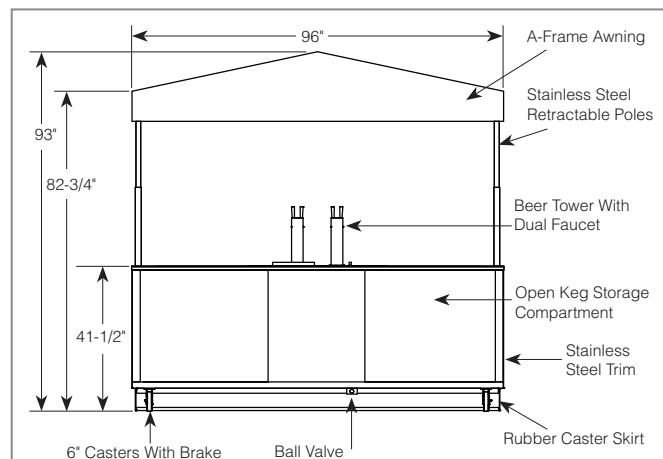
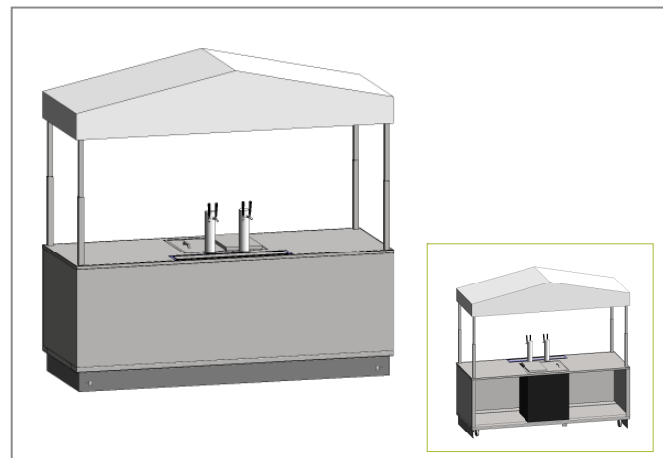

All fixtures and equipment to be connected to a single load center. Cart to have one (1) 8' power cable with a NEMA 5-20P plug.

**PLUMBING NOTES**

Ice bins to drain to a ball valve located below the cart.

Drip trough to drain to a ball valve located below the cart.