

GENERAL INFORMATION

Project Name: _____
Item: _____
Quantity: _____
Model: CUSTOM COLD FOOD CART
Length: _____

STANDARD FEATURES

- Laminate countertop with t-mold edges
- Mahogany stained body
- Mahogany stained trim
- Mahogany stained push handles
- 32" diameter hardwood spoke wheels
- 6" swivel caster with brake
- Mahogany stained caster support with metal support
- Drop-in 2-pan cold food well
- Locking storage compartment (both ends)
- Mahogany stained awning posts
- A-frame awning with Sunbrella covering
- U.L. Listed
- NSF Listed to Standard 59

OPTIONS

- Drop shelf
- Round awning
- Custom colors
- Custom graphics
- Menu board
- Track lights
- Cart cover
- Portable waste tank

ELECTRICAL REQUIREMENTS

- 120 Volt / 1 Phase / 15 Amp

CUSTOM COLD FOOD CART

5' Wood Merchandise Cart

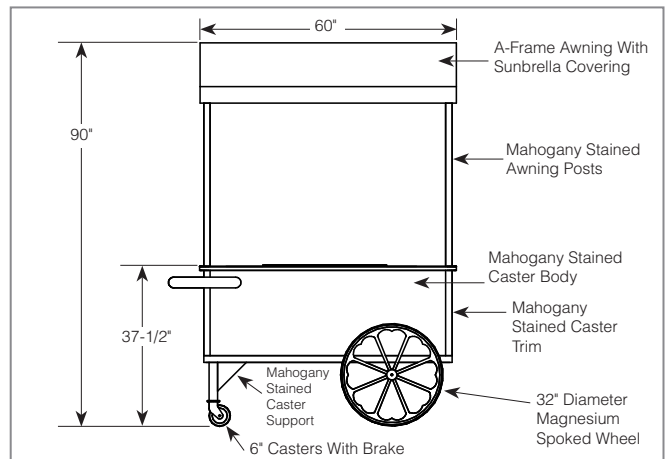
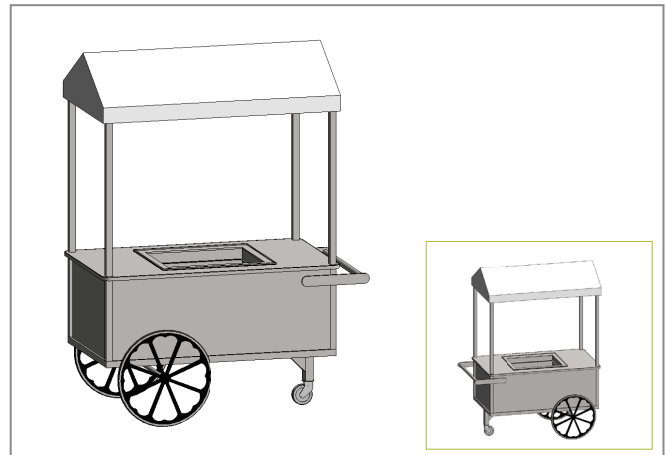

All fixtures and equipment to be connected to a single load center. Cart to have one (1) 8' power cable with a NEMA 5-15P plug.