

GENERAL INFORMATION

Project Name: _____
Item: _____
Quantity: _____
Model: CUSTOM GRILL CART
Length: _____

STANDARD FEATURES

- 16 gauge #304 stainless steel countertop
- 18 gauge #304 stainless steel trim
- 6" casters, two (2) rigid and two (2) swivel with brakes
- Black rubber caster skirt on three (3) sides
- Hand sink with removable water tanks
- Stainless steel - glass food guard
- Stainless steel round retractable awning poles
- A-Frame awning with fabric covering (red, blue or yellow)
- All tanks, valves, piping and fittings to comply with all NSF, local, state and federal health codes and standards
- U.L. Listed
- NSF Listed to Standard 59

OPTIONS

- Quilted stainless steel exterior panels
- Drop deck with open storage below
- Vinyl bumper
- Square awning poles
- Fixed awning poles
- Drop shelf
- Round awning
- Custom exterior panels (laminated, stainless steel, powder coat, etc.)
- Custom colors
- Custom graphics
- Menu board
- Track lights
- Cart cover

EQUIPMENT SUPPLIED

- 3' grill
- Undercounter refrigeration

ELECTRICAL REQUIREMENTS

- 120/208 Volt / 1 Phase / 50 Amp

CUSTOM GRILL CART
8' Cart

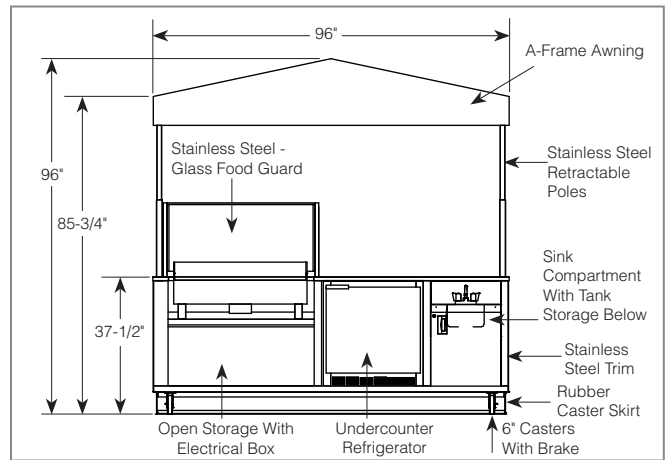
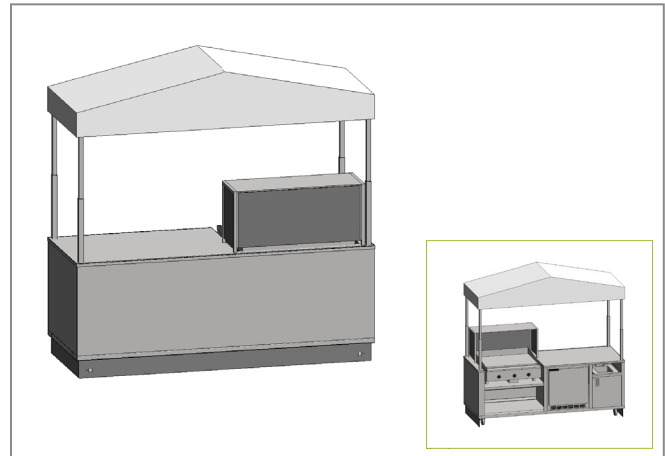

All fixtures and equipment to be connected to a single load center. Cart to have one (1) 8' power cable with a NEMA 14-50P plug.

PLUMBING NOTES

- One (1) 5-1/2 gallon fresh water tote tank
- One (1) 7-1/2 gallon waste water tote tank
- One (1) water pump
- One (1) 2-1/2 gallon hot water heater
- One (1) 2-compartment stainless steel hand sink with two (2) 6-1/8" x 12-1/8" x 5" deep bowls

Fresh and waste water tanks to be accessible from operator side and are removable with quick disconnects for ease of cleaning.

Water heater to deliver water to hand sink between a minimum of 80°F and a maximum of 120°F.