

GENERAL INFORMATION

Project Name: _____
Item: _____
Quantity: _____
Model: CUSTOM SINK CART
Length: _____

STANDARD FEATURES

- 16 gauge #304 stainless steel countertop
- 18 gauge #304 stainless steel trim
- 6" casters, two (2) rigid and two (2) swivel with brakes
- Black rubber caster skirt on three (3) sides
- Stainless steel exterior panels
- Sink compartment with tank storage below
- Stainless steel splash guard
- All tanks, valves, piping and fittings to comply with all NSF, local, state and federal health codes and standards
- U.L. Listed
- NSF Listed to Standard 59

OPTIONS

- Custom panels (powder coated metal, laminate, stainless steel, etc.)
- Custom tops (corian, granite, etc.)
- Black vinyl bumper
- Custom graphics
- Cart cover

ELECTRICAL REQUIREMENTS

- 120 Volt / 1 Phase / 20 Amp

NOTE: Water system does not provide water for human consumption.

CUSTOM SINK CART

3', Three Compartment Cart

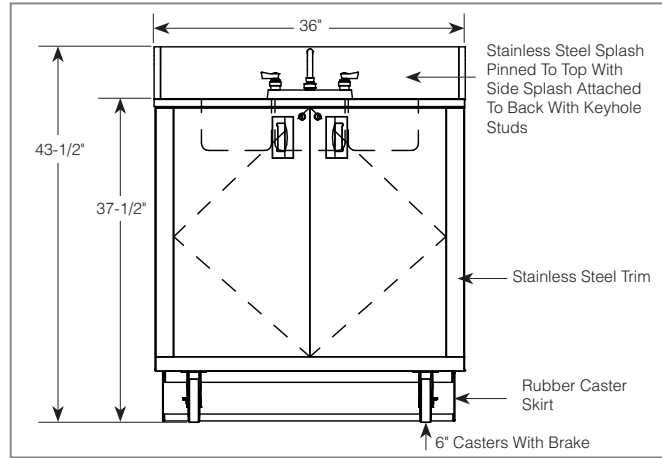
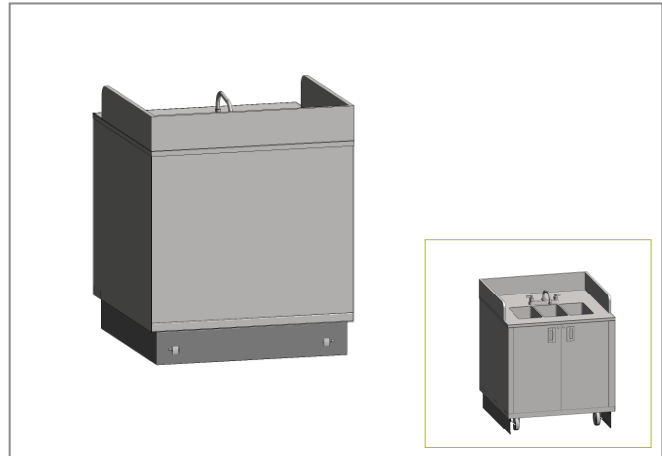

All fixtures and equipment to be connected to a single load center. Cart to have one (1) 8' power cable with a NEMA 5-20P plug.

PLUMBING NOTES

- One (1) 5-1/2 gallon fresh water tote tank
- One (1) 7-1/2 gallon waste water tote tank
- One (1) water pump
- One (1) 2-1/2 gallon hot water heater
- One (1) 2-compartment stainless steel hand sink with two (2) 6-1/8" x 12-1/8" x 5" deep bowls

Fresh and waste water tanks to be accessible from operator side and are removable with quick disconnects for ease of cleaning.

Water heater to deliver water to hand sink between a minimum of 80°F and a maximum of 120°F.