

**CUSTOM MODELS**

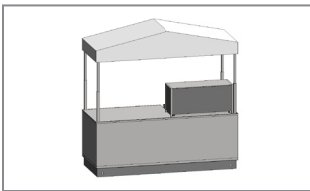

GRILL CART

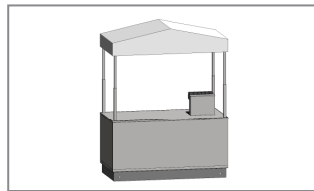

POST-MIX SODA CART

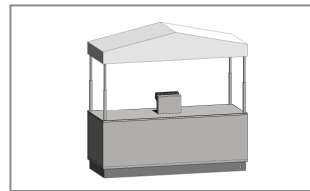

POST-MIX SODA CART

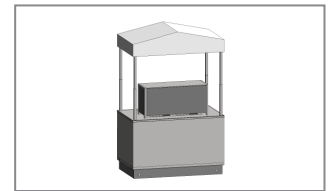

BEVERAGE CART

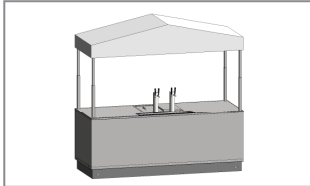

DRAFT BEER CART

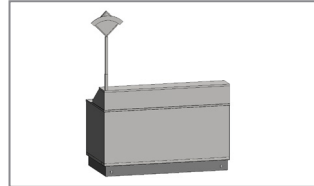

BAR CART

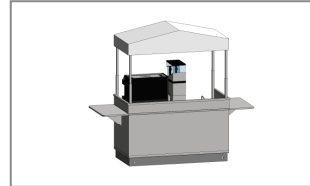

COFFEE CART

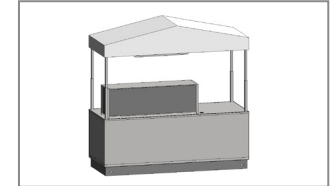

SMOOTHIE CART

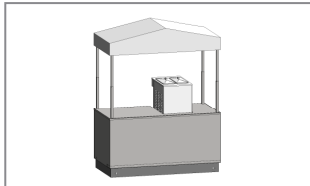

SOFT-SERVE CART

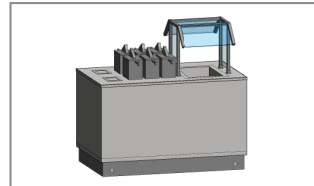

CONDIMENT CART

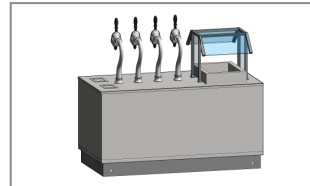

CONDIMENT CART

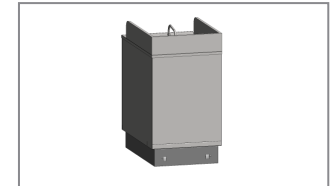

HAND WASH CART

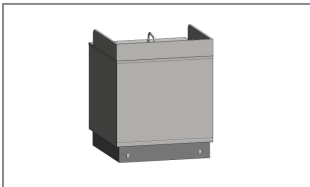

SINK CART

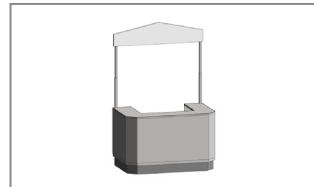

INFORMATION CART

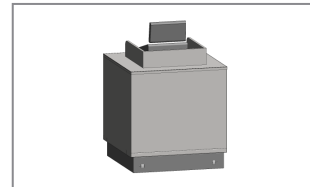

CASH CART

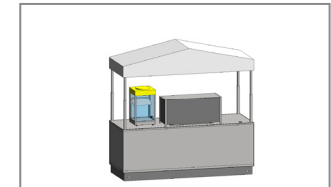

NACHO CART

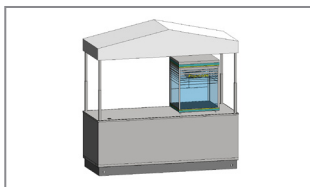

POPCORN CART



COLD FOOD CART



COLD FOOD CART



HOT FOOD CART



COLD/HOT FOOD CART

**GENERAL INFORMATION**

**Project Name:** \_\_\_\_\_  
**Item:** \_\_\_\_\_  
**Quantity:** \_\_\_\_\_  
**Model:** CUSTOM GRILL CART  
**Length:** \_\_\_\_\_

**STANDARD FEATURES**

- 16 gauge #304 stainless steel countertop
- 18 gauge #304 stainless steel trim
- 6" casters, two (2) rigid and two (2) swivel with brakes
- Black rubber caster skirt on three (3) sides
- Hand sink with removable water tanks
- Stainless steel - glass food guard
- Stainless steel round retractable awning poles
- A-Frame awning with fabric covering (red, blue or yellow)
- All tanks, valves, piping and fittings to comply with all NSF, local, state and federal health codes and standards
- U.L. Listed
- NSF Listed to Standard 59

**OPTIONS**

- Quilted stainless steel exterior panels
- Drop deck with open storage below
- Vinyl bumper
- Square awning poles
- Fixed awning poles
- Drop shelf
- Round awning
- Custom exterior panels (laminated, stainless steel, powder coat, etc.)
- Custom colors
- Custom graphics
- Menu board
- Track lights
- Cart cover

**EQUIPMENT SUPPLIED**

- 3' grill
- Undercounter refrigeration

**ELECTRICAL REQUIREMENTS**

- 120/208 Volt / 1 Phase / 50 Amp

**CUSTOM GRILL CART**  
8' Cart

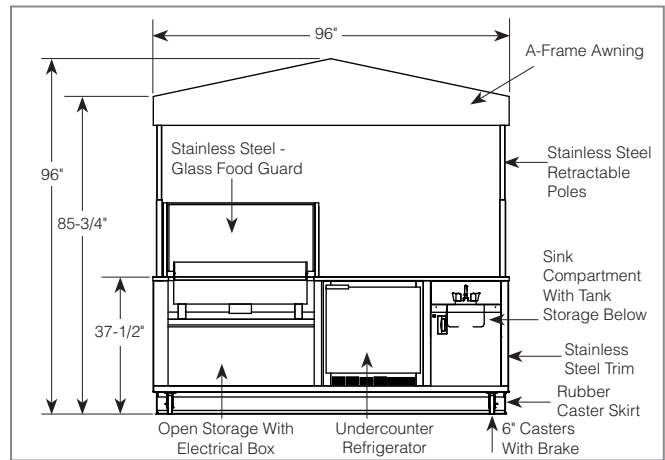
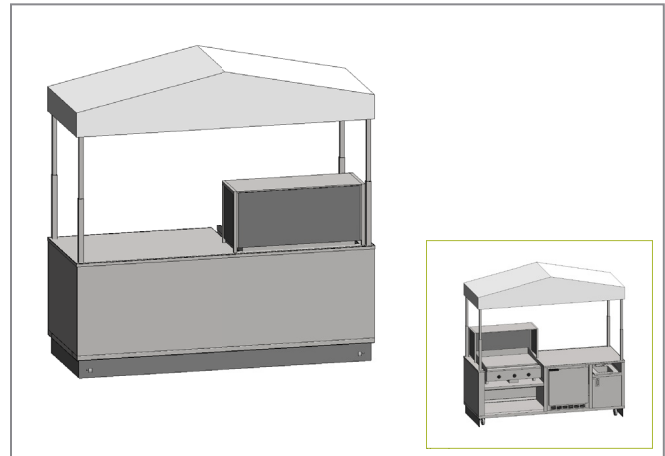

All fixtures and equipment to be connected to a single load center. Cart to have one (1) 8' power cable with a NEMA 14-50P plug.

**PLUMBING NOTES**

- One (1) 5-1/2 gallon fresh water tote tank
- One (1) 7-1/2 gallon waste water tote tank
- One (1) water pump
- One (1) 2-1/2 gallon hot water heater
- One (1) 2-compartment stainless steel hand sink with two (2) 6-1/8" x 12-1/8" x 5" deep bowls

Fresh and waste water tanks to be accessible from operator side and are removable with quick disconnects for ease of cleaning.

Water heater to deliver water to hand sink between a minimum of 80°F and a maximum of 120°F.

**GENERAL INFORMATION**

**Project Name:** \_\_\_\_\_  
**Item:** \_\_\_\_\_  
**Quantity:** \_\_\_\_\_  
**Model:** CUSTOM POST-MIX CART  
**Length:** \_\_\_\_\_

**STANDARD FEATURES**

- 16 gauge #304 stainless steel countertop
- 18 gauge #304 stainless steel trim
- 6" casters, two (2) rigid and two (2) swivel with brakes
- Black rubber caster skirt on three (3) sides
- Powder coated exterior panels (red, blue or yellow)
- Open storage compartment for soda system
- Stainless steel round retractable awning poles
- A-Frame awning with fabric covering (red, blue or yellow)
- 20 gallon fresh water tank
- 7-1/2 gallon waste water tank
- All tanks, valves, piping and fittings to comply with all NSF, local, state and federal health codes and standards
- U.L. Listed
- NSF Listed to Standard 59

**OPTIONS**

- Cash drawer
- Recessed canister lights
- Vinyl bumper
- Square awning poles
- Fixed awning poles
- Drop shelf
- Round awning
- Custom exterior panels (laminated, stainless steel, powder coat, etc.)
- Custom colors
- Custom graphics
- Menu board
- Track lights
- Cart cover

**EQUIPMENT SUPPLIED BY OTHERS**

- 1522 Post-mix beverage tower
- Bag-n-box beverage system
- CO2 tank

**CUSTOM POST-MIX CART**

6' Cart

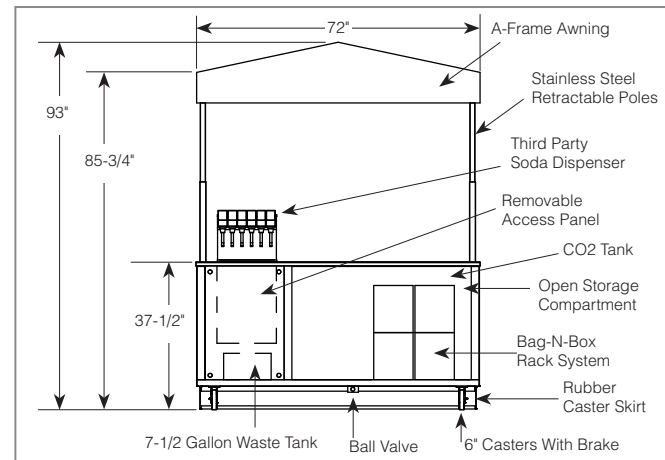
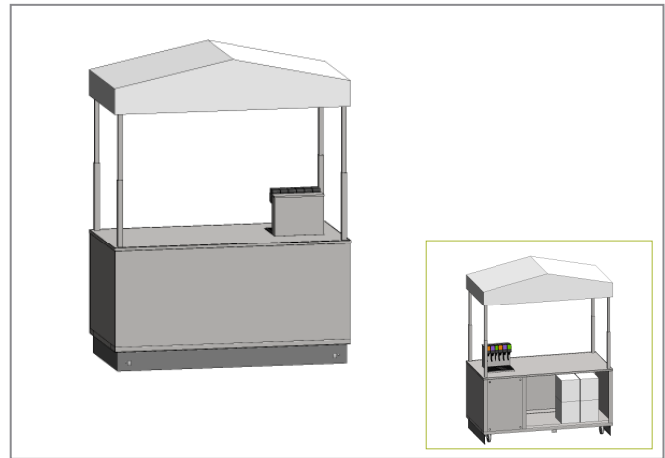

All fixtures and equipment to be connected to a single load center. Cart to have one (1) 8' power cable with a NEMA 5-20P plug.

**ELECTRICAL REQUIREMENTS**

- 120 Volt / 1 Phase / 20 Amp

**PLUMBING NOTES**

Cart's beverage system to be installed by beverage equipment purveyor.

**GENERAL INFORMATION**

**Project Name:** \_\_\_\_\_  
**Item:** \_\_\_\_\_  
**Quantity:** \_\_\_\_\_  
**Model:** CUSTOM POST-MIX CART  
**Length:** \_\_\_\_\_

**STANDARD FEATURES**

- 16 gauge #304 stainless steel countertop
- 18 gauge #304 stainless steel trim
- 6" casters, two (2) rigid and two (2) swivel with brakes
- Black rubber caster skirt on three (3) sides
- Powder coated exterior panels (red, blue or yellow)
- Open storage compartment for soda system
- Stainless steel round retractable awning poles
- A-Frame awning with fabric covering (red, blue or yellow)
- 20 gallon fresh water tank
- 7-1/2 gallon waste water tank
- All tanks, valves, piping and fittings to comply with all NSF, local, state and federal health codes and standards
- U.L. Listed
- NSF Listed to Standard 59

**OPTIONS**

- Cash drawer
- Recessed canister lights
- Vinyl bumper
- Square awning poles
- Fixed awning poles
- Drop shelf
- Round awning
- Custom exterior panels (laminated, stainless steel, powder coat, etc.)
- Custom colors
- Custom graphics
- Menu board
- Track lights
- Cart cover

**EQUIPMENT SUPPLIED BY OTHERS**

- 2323 Post-mix beverage tower
- Bag-n-box beverage system
- CO2 tank

**ELECTRICAL REQUIREMENTS**

- 120 Volt / 1 Phase / 20 Amp

**CUSTOM POST-MIX CART**

8' Cart

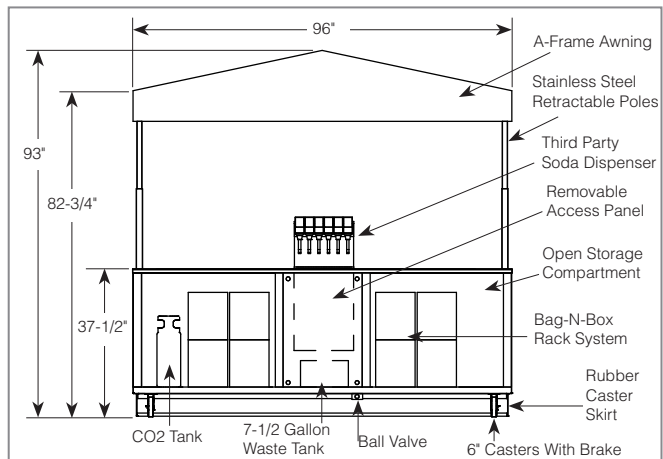
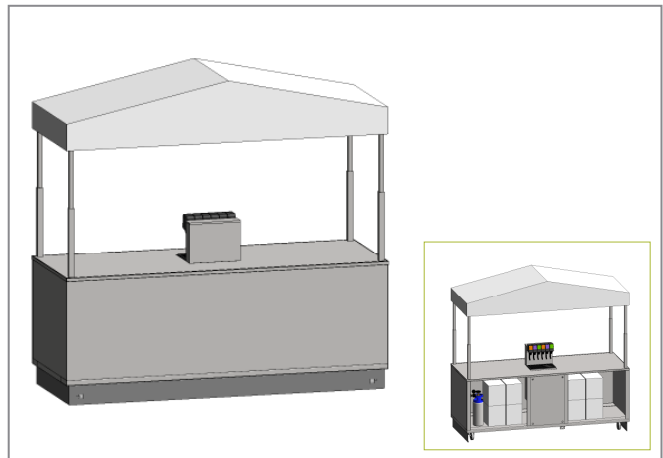

All fixtures and equipment to be connected to a single load center. Cart to have one (1) 8' power cable with a NEMA 5-20P plug.

**PLUMBING NOTES**

Cart's beverage system to be installed by beverage equipment purveyor.

**GENERAL INFORMATION**

**Project Name:** \_\_\_\_\_  
**Item:** \_\_\_\_\_  
**Quantity:** \_\_\_\_\_  
**Model:** CUSTOM BEVERAGE CART  
**Length:** \_\_\_\_\_

**STANDARD FEATURES**

- 16 gauge #304 stainless steel countertop
- 18 gauge #304 stainless steel trim
- 6" casters, two (2) rigid and two (2) swivel with brakes
- Black rubber caster skirt on three (3) sides
- Powder coated exterior panels (red, blue or yellow)
- Stainless steel apron
- Stainless steel - glass food guard
- Two (2) roto molded ice bins
- Stainless steel round retractable awning poles
- A-Frame awning with fabric covering (red, blue or yellow)
- All tanks, valves, piping and fittings to comply with all NSF, local, state and federal health codes and standards
- U.L. Listed
- NSF Listed to Standard 59

**OPTIONS**

- Removable stainless steel cup shelf
- Bottle openers
- Metal cash drawer
- Vinyl bumper
- Square awning poles
- Fixed awning poles
- Drop shelf
- Round awning
- Custom exterior panels (laminated, stainless steel, powder coat, etc.)
- Custom colors
- Custom graphics
- Menu board
- Track lights
- Cart cover
- Portable waste tank

**ELECTRICAL REQUIREMENTS**

- 120 Volt / 1 Phase / 20 Amp

**CUSTOM BEVERAGE CART**

*5' Bottled Cart*

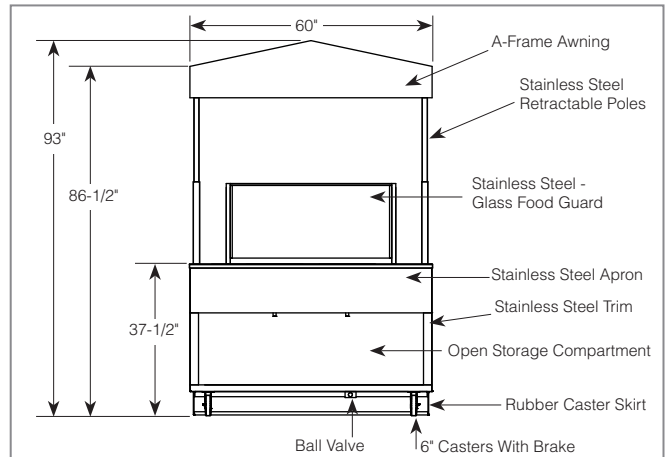
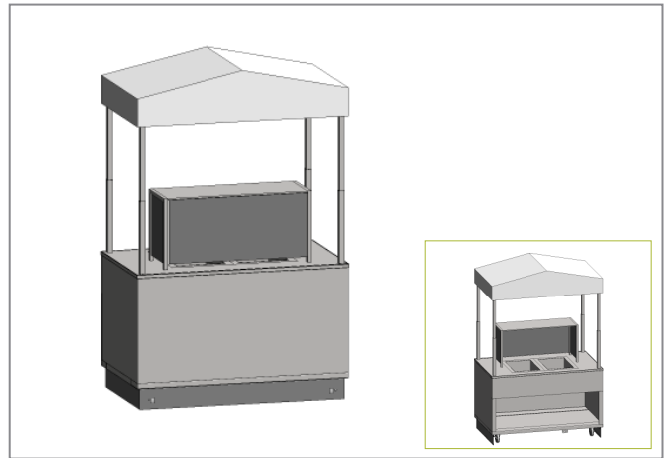

All fixtures and equipment to be connected to a single load center. Cart to have one (1) 8' power cable with a NEMA 5-20P plug.

**PLUMBING NOTES**

Ice bins to drain to a ball valve located below the cart.

**GENERAL INFORMATION**

**Project Name:** \_\_\_\_\_  
**Item:** \_\_\_\_\_  
**Quantity:** \_\_\_\_\_  
**Model:** CUSTOM BEER CART  
**Length:** \_\_\_\_\_

**STANDARD FEATURES**

- 16 gauge #304 stainless steel countertop
- 18 gauge #304 stainless steel trim
- 6" casters, two (2) rigid and two (2) swivel with brakes
- Black rubber caster skirt on three (3) sides
- Powder coated exterior panels (red, blue or yellow)
- Open keg storage compartment
- Stainless steel drip trough
- Stainless steel ice bin with lid and cold plate
- Stainless steel round retractable awning poles
- A-Frame awning with fabric covering (red, blue or yellow)
- Beer Tower - dual faucet
- 4 - Product cold plate (inside ice bin)
- All tanks, valves, piping and fittings to comply with all NSF, local, state and federal health codes and standards
- U.L. Listed
- NSF Listed to Standard 59

**OPTIONS**

- Removable stainless steel cup shelf
- Metal cash drawer
- Vinyl bumper
- Square awning poles
- Fixed awning poles
- Drop shelf
- Round awning
- Custom exterior panels (laminated, stainless steel, powder coat, etc.)
- Custom colors
- Custom graphics
- Menu board
- Track lights
- Cart cover
- Portable waste tank

**ELECTRICAL REQUIREMENTS**

- 120 Volt / 1 Phase / 20 Amp

Specifications subject to change without notice.

**CUSTOM BEER CART**  
4 Keg Draft Beer

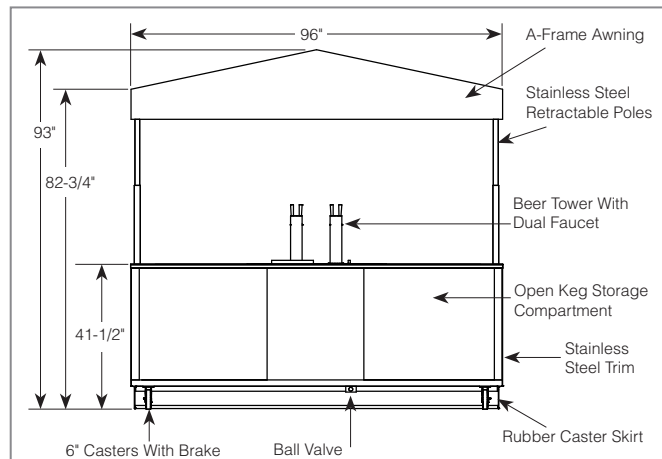
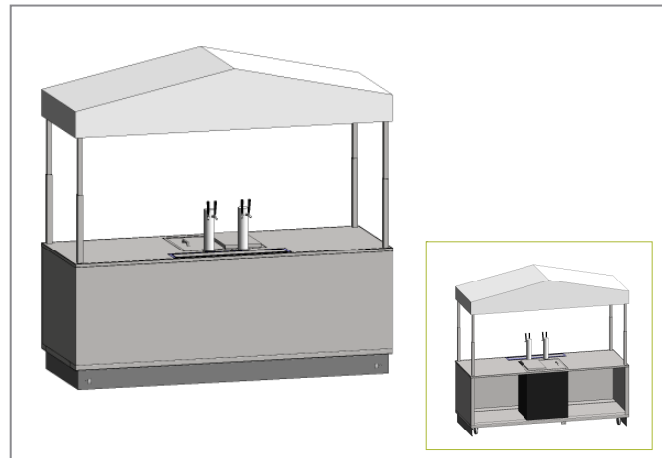

All fixtures and equipment to be connected to a single load center. Cart to have one (1) 8' power cable with a NEMA 5-20P plug.

**PLUMBING NOTES**

Ice bins to drain to a ball valve located below the cart.

Drip trough to drain to a ball valve located below the cart.

**GENERAL INFORMATION**

**Project Name:** \_\_\_\_\_  
**Item:** \_\_\_\_\_  
**Quantity:** \_\_\_\_\_  
**Model:** CUSTOM BAR CART  
**Length:** \_\_\_\_\_

**STANDARD FEATURES**

- 16 gauge #304 stainless steel countertop
- Laminate exterior panels  
Stainless steel interior
- 6" casters, two (2) rigid and two (2) swivel with brakes
- Black rubber caster skirt on three (3) sides
- Open storage compartment for beverage system
- Stainless steel ice bin with drain and 7-1/2 gallon waste water tank
- Laminate bar top
- Removable speed rail
- All tanks, valves, piping and fittings to comply with all NSF, local, state and federal health codes and standards
- U.L. Listed
- NSF Listed to Standard 59

**OPTIONS**

- Custom panels (powder coated metal, wood veneer, stainless steel, etc.)
- Custom tops (corian, granite, etc)
- Diamond signage with graphics
- Rubber bumper
- Refrigerated power pack and support cart
- Post-mix system
- Pre-mix system
- Bottle and can rack

**ELECTRICAL REQUIREMENTS**

- 120Volt / 1 Phase / 15 Amp
- Optional convience outlet, otherwise no power

**CUSTOM BAR CART**  
6' Cart

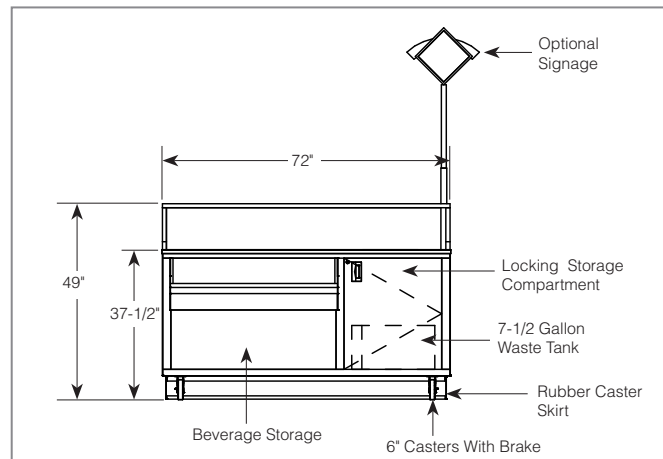
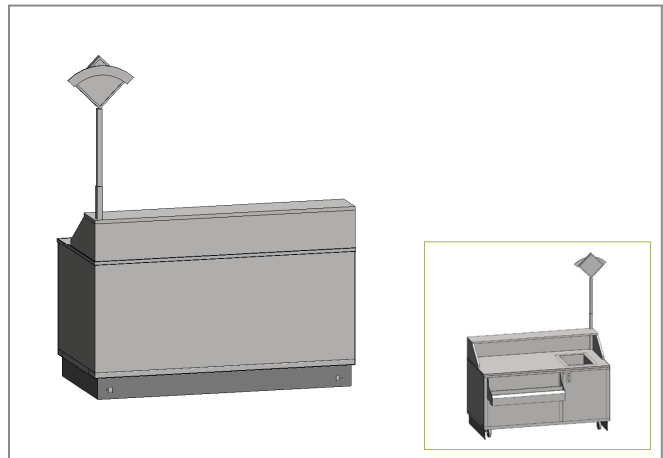

All fixtures and equipment to be connected to a single load center. Cart to have one (1) 8' power cable with a NEMA 5-15P plug.

**PLUMBING PROVIDED**

Ice bins to drain to a ball valve located below the cart.

**GENERAL INFORMATION**

**Project Name:** \_\_\_\_\_  
**Item:** \_\_\_\_\_  
**Quantity:** \_\_\_\_\_  
**Model:** CUSTOM COFFEE CART  
**Length:** \_\_\_\_\_

**STANDARD FEATURES**

- Laminate countertop
- 6" casters, two (2) rigid and two (2) swivel with brakes
- Black rubber caster skirt on three (3) sides
- Black laminate exterior panels
- Laminate drop shelves with T-mold edging
- Laminate raised shelf with PVC edge
- Hand sink with removable water tanks
- Locking storage compartment
- Stainless steel round retractable awning poles
- A-Frame awning with fabric covering (red, blue or yellow)
- Track lighting
- All tanks, valves, piping and fittings to comply with all NSF, local, state and federal health codes and standards
- U.L. Listed
- NSF Listed to Standard 59

**OPTIONS**

- Vinyl bumper colors
- Fixed awning poles
- Round awning
- Custom exterior panels (powder coated metal, stainless steel, etc.)
- Custom colors
- Custom graphics
- Menu board
- Spot lights
- Cart cover
- Portable waste tank

**EQUIPMENT SUPPLIED**

- Undercounter refrigerator

**EQUIPMENT SUPPLIED OTHERS**

- Espresso machine
- Coffee grinder

**ELECTRICAL REQUIREMENTS**

- 120/208 Volt / 1 Phase / 50 Amp

Specifications subject to change without notice.

**CUSTOM COFFEE CART**

6' Cart

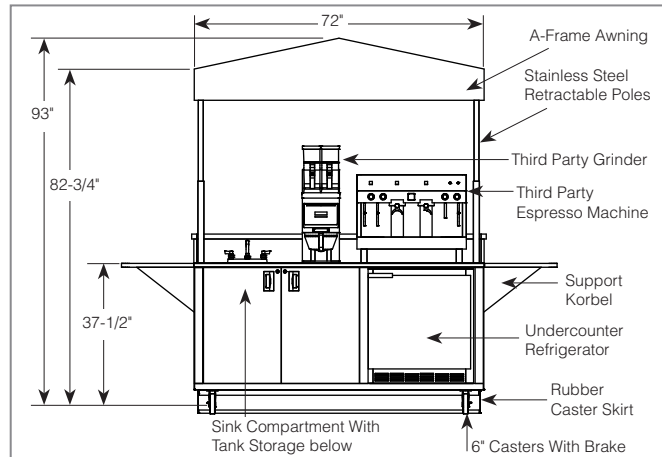
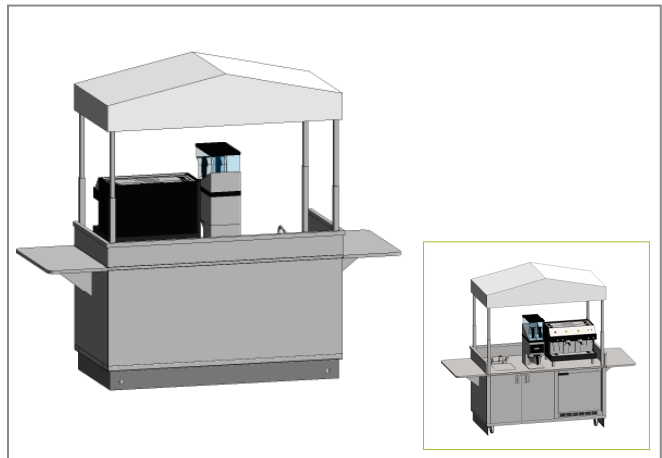

All fixtures and equipment to be connected to a single load center. Cart to have one (1) 8' power cable with a NEMA 14-50P plug.

**PLUMBING NOTES**

- One (1) 5-1/2 gallon fresh water tote tank
- One (1) 7-1/2 gallon waste water tote tank
- One (1) water pump
- One (1) 2-1/2 gallon hot water heater
- One (1) 2-compartment stainless steel hand sink with two (2) 6-1/8" x 12-1/8" x 5" deep bowls

Fresh and waste water tanks to be accessible from operator side and are removable with quick disconnects for ease of cleaning.

Water heater to deliver water to hand sink between a minimum of 80°F and a maximum of 120°F.



**GENERAL INFORMATION**

**Project Name:** \_\_\_\_\_  
**Item:** \_\_\_\_\_  
**Quantity:** \_\_\_\_\_  
**Model:** CUSTOM SMOOTHIE CART  
**Length:** \_\_\_\_\_

**STANDARD FEATURES**

- 16 gauge #304 stainless steel countertop
- 18 gauge #304 stainless steel trim
- 6" casters, two (2) rigid and two (2) swivel with brakes
- Black rubber caster skirt on three (3) sides
- Black vinyl bumper on three (3) sides
- Powder coated exterior panels (red, blue or yellow)
- Electrical compartment
- Locking storage compartment
- Drop-in ice bin with hinged and locking lid
- Drop-in hand sink with faucet (single bowl)
- BSI DECO-204 food guard
- Stainless steel round retractable awning poles
- A-Frame awning with fabric covering (red, blue or yellow)
- Track lighting
- All tanks, valves, piping and fittings to comply with all NSF, local, state and federal health codes and standards
- U.L. Listed
- NSF Listed to Standard 59

**OPTIONS**

- Vinyl bumper colors
- Square awning poles
- Fixed awning poles
- Drop shelf
- Round awning
- Custom exterior panels (laminated, stainless steel, powder coat, etc.)
- Custom colors
- Custom graphics
- Menu board
- Spot lights
- Recessed canister lights
- Cart cover

**ELECTRICAL REQUIREMENTS**

- 120/208 Volt / 1 Phase / 50 Amp

**CUSTOM SMOOTHIE CART**

8' Cart

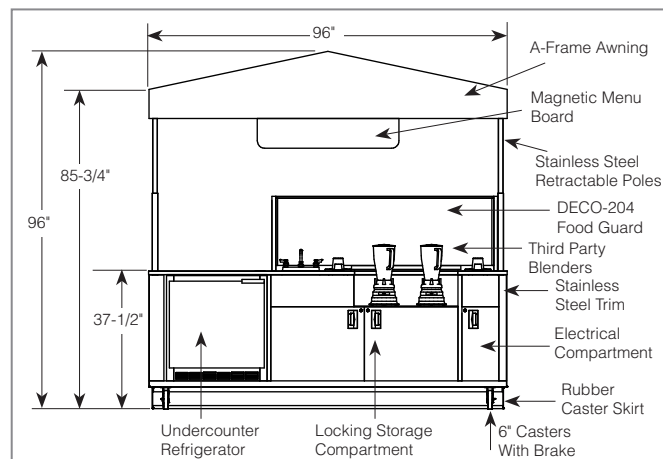
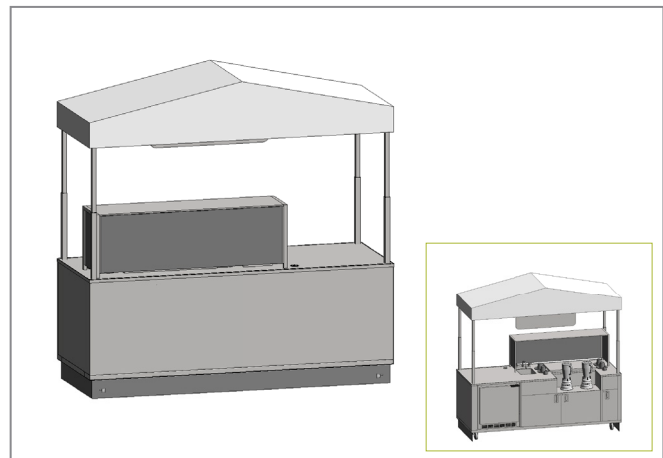

All fixtures and equipment to be connected to a single load center. Cart to have one (1) 8' power cable with a NEMA 14-50P plug.

**PLUMBING PROVIDED**

- One (1) 5-1/2 gallon fresh water tote tank
- One (1) 7-1/2 gallon waste water tote tank
- One (1) water pump
- One (1) 2-1/2 gallon hot water heater
- One (1) 2-compartment stainless steel hand sink with two (2) 6-1/8" x 12-1/8" x 5" deep bowls

Fresh and waste water tanks to be accessible from operator side and are removable with quick disconnects for ease of cleaning.

Water heater to deliver water to hand sink between a minimum of 80°F and a maximum of 120°F.

The ice bin to drain to the same 7-1/2 gallon waste tank as the sink.

**GENERAL INFORMATION**

**Project Name:** \_\_\_\_\_  
**Item:** \_\_\_\_\_  
**Quantity:** \_\_\_\_\_  
**Model:** CUSTOM SOFT-SERVE CART  
**Length:** \_\_\_\_\_

**STANDARD FEATURES**

- 16 gauge #304 stainless steel countertop
- 18 gauge #304 stainless steel trim
- 6" casters, two (2) rigid and two (2) swivel with brakes
- Black rubber caster skirt on three (3) sides
- Hand sink with removable water tanks
- Roll-in third party soft serve machine
- Locking power compartment
- Stainless steel round retractable awning poles
- A-Frame awning with fabric covering (red, blue or yellow)
- All tanks, valves, piping and fittings to comply with all NSF, local, state and federal health codes and standards
- U.L. Listed
- NSF Listed to Standard 59

**OPTIONS**

- Vinyl bumper colors
- Square awning poles
- Fixed awning poles
- Drop shelf
- Round awning
- Custom exterior panels (laminated, stainless steel, powder coat, etc.)
- Custom colors
- Custom graphics
- Menu board
- Track lights
- Cart cover
- Soft-Serve Ice Cream Machine by others.

**ELECTRICAL REQUIREMENTS**

- 120/208 Volt / 1 Phase / 50 Amp

**CUSTOM SOFT-SERVE CART**

6' Cart

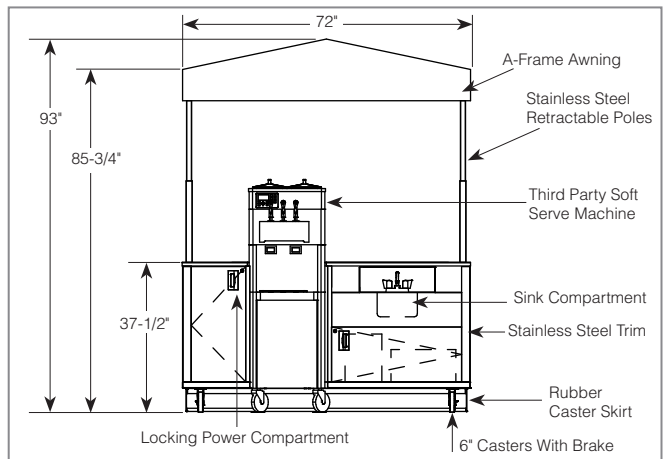
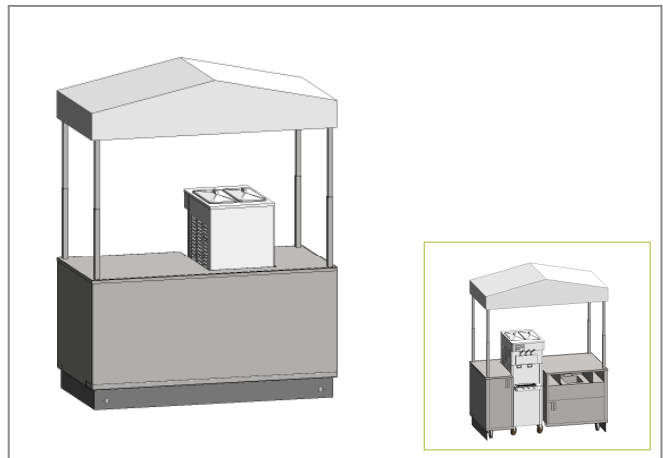

All fixtures and equipment to be connected to a single panel for one point connection load center. Cart to have one (1) 8' power cable with a NEMA 14-50P plug.

**PLUMBING PROVIDED**

- One (1) 5-1/2 gallon fresh water tote tank
- One (1) 7-1/2 gallon waste water tote tank
- One (1) water pump
- One (1) 2-1/2 gallon hot water heater
- One (1) 2-compartment stainless steel hand sink with two (2) 6-1/8" x 12-1/8" x 5" deep bowls

Fresh and waste water tanks to be accessible from operator side and are removable with quick disconnects for ease of cleaning.

Water heater to deliver water to hand sink between a minimum of 80°F and a maximum of 120°F.

**GENERAL INFORMATION**

**Project Name:** \_\_\_\_\_  
**Item:** \_\_\_\_\_  
**Quantity:** \_\_\_\_\_  
**Model:** CUSTOM CONDIMENT CART  
**Length:** \_\_\_\_\_

**STANDARD FEATURES**

- 16 gauge #304 stainless steel countertop
- 18 gauge #304 stainless steel trim
- 6" casters, two (2) rigid and two (2) swivel with brakes
- Black rubber caster skirt on three (3) sides
- Powder coated exterior panels
- Locking stainless steel storage compartment
- Stainless steel - glass food guard
- Stainless steel ice bin (drop-in)
- U.L. Listed
- NSF Listed to Standard 59

**OPTIONS**

- Drop shelf
- Vinyl bumper
- Custom graphics
- Cart cover

**EQUIPMENT SUPPLIED**

- Condiment pumps
- Napkin dispensers

**CUSTOM CONDIMENT CART**

5' Cart

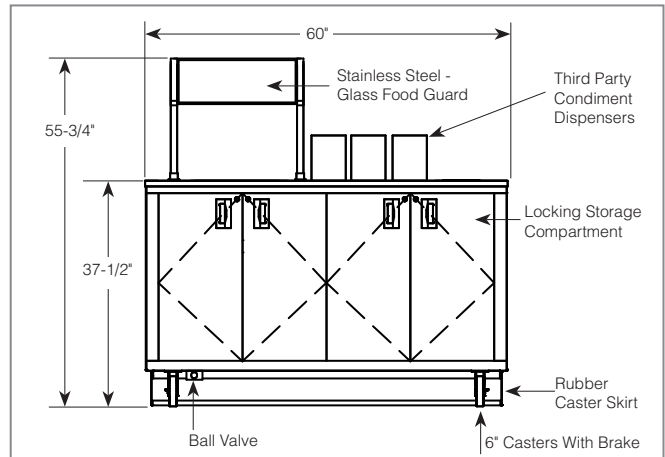
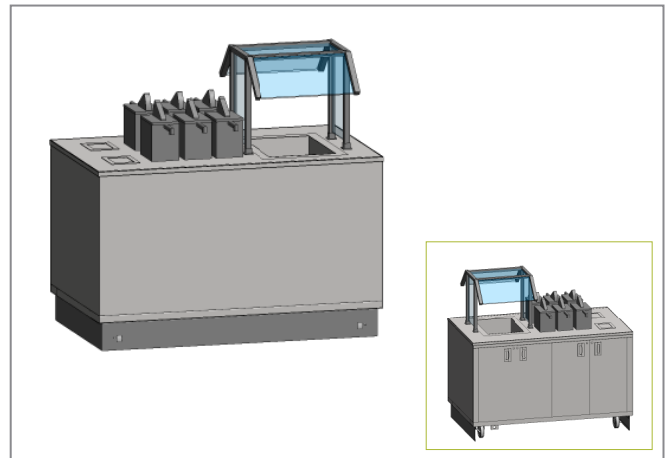

**PLUMBING NOTES**

Ice bins to drain to a ball valve located below the cart.

**GENERAL INFORMATION**

**Project Name:** \_\_\_\_\_  
**Item:** \_\_\_\_\_  
**Quantity:** \_\_\_\_\_  
**Model:** CUSTOM CONDIMENT CART  
**Length:** \_\_\_\_\_

**STANDARD FEATURES**

- 16 gauge #304 stainless steel countertop
- 18 gauge #304 stainless steel trim
- 6" casters, two (2) rigid and two (2) swivel with brakes
- Black rubber caster skirt on three (3) sides
- Powder coated exterior panels
- Locking stainless steel storage compartment
- Stainless steel - glass food guard
- Stainless steel ice bin (drop-in)
- U.L. Listed
- NSF Listed to Standard 59

**OPTIONS**

- Drop shelf
- Vinyl bumper
- Custom graphics
- Cart cover

**EQUIPMENT SUPPLIED**

- Automatic condiment dispensers
- Napkin dispensers
- Undercounter refrigerator
- Bag-n-box slide out rack system for condiments

**EQUIPMENT SUPPLIED OTHERS**

- CO2 tank - 10 pound

**CUSTOM CONDIMENT CART**

6' Cart (with CO2 Dispensing System)

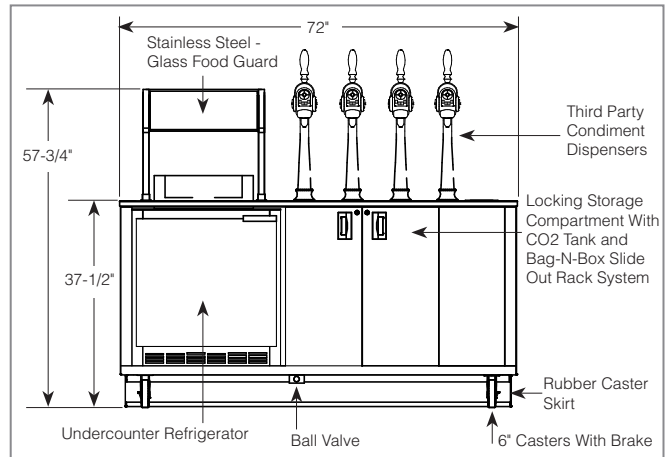
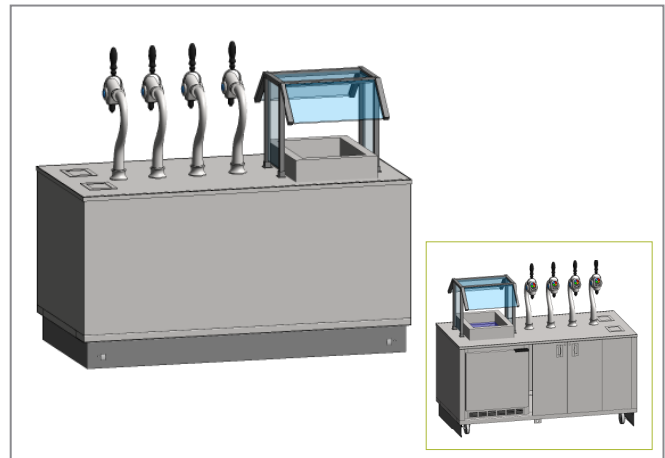

All fixtures and equipment to be connected to a single load center. Cart to have one (1) 8' power cable with a NEMA 5-20P plug.

**PLUMBING NOTES**

Ice bins to drain to a ball valve located below the cart.

**GENERAL INFORMATION**

**Project Name:** \_\_\_\_\_  
**Item:** \_\_\_\_\_  
**Quantity:** \_\_\_\_\_  
**Model:** CUSTOM HAND WASH CART  
**Length:** \_\_\_\_\_

**STANDARD FEATURES**

- 16 gauge #304 stainless steel countertop
- 18 gauge #304 stainless steel trim
- 6" casters, two (2) rigid and two (2) swivel with brakes
- Black rubber caster skirt on three (3) sides
- Stainless steel exterior panels
- Sink compartment with tank storage below
- Stainless steel splash guard
- All tanks, valves, piping and fittings to comply with all NSF, local, state and federal health codes and standards
- U.L. Listed
- NSF Listed to Standard 59

**OPTIONS**

- Custom panels (powder coated metal, laminate, stainless steel, etc.)
- Custom tops (corian, granite, etc.)
- Black vinyl bumper
- Custom graphics
- Cart cover

**ELECTRICAL REQUIREMENTS**

- 120 Volt / 1 Phase / 20 Amp

**NOTE: Water system does not provide water for human consumption.**

**CUSTOM HAND WASH CART**

2' Cart

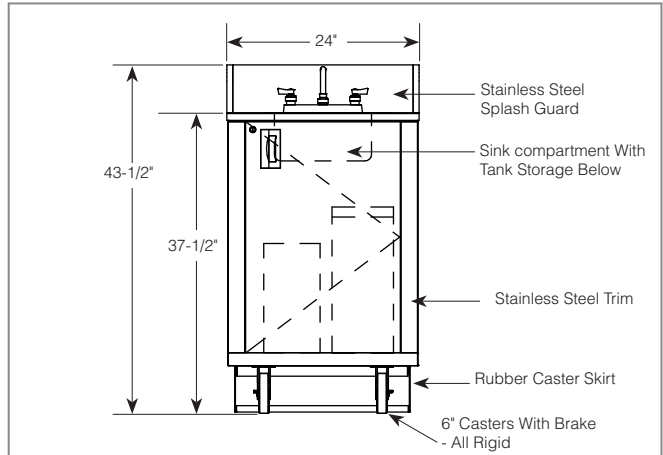
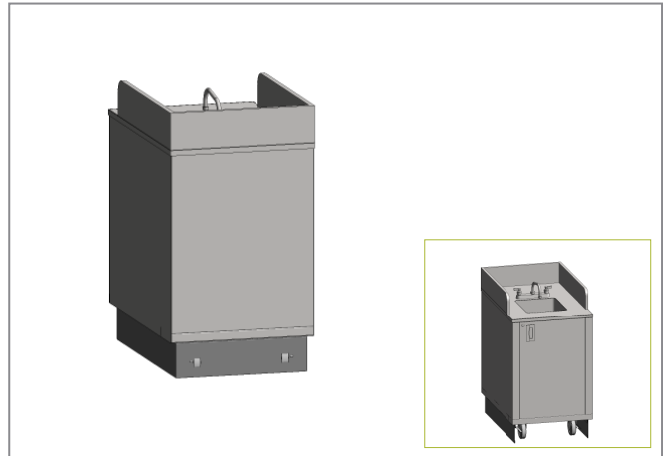

All fixtures and equipment to be connected to a single load center. Cart to have one (1) 8' power cable with a NEMA 5-20P plug.

**PLUMBING NOTES**

- One (1) 5-1/2 gallon fresh water tote tank
- One (1) 7-1/2 gallon waste water tote tank
- One (1) water pump
- One (1) 2-1/2 gallon hot water heater
- One (1) 2-compartment stainless steel hand sink with two (2) 6-1/8" x 12-1/8" x 5" deep bowls

Fresh and waste water tanks to be accessible from operator side and are removable with quick disconnects for ease of cleaning.

Water heater to deliver water to hand sink between a minimum of 80°F and a maximum of 120°F.

**GENERAL INFORMATION**

**Project Name:** \_\_\_\_\_  
**Item:** \_\_\_\_\_  
**Quantity:** \_\_\_\_\_  
**Model:** CUSTOM SINK CART  
**Length:** \_\_\_\_\_

**STANDARD FEATURES**

- 16 gauge #304 stainless steel countertop
- 18 gauge #304 stainless steel trim
- 6" casters, two (2) rigid and two (2) swivel with brakes
- Black rubber caster skirt on three (3) sides
- Stainless steel exterior panels
- Sink compartment with tank storage below
- Stainless steel splash guard
- All tanks, valves, piping and fittings to comply with all NSF, local, state and federal health codes and standards
- U.L. Listed
- NSF Listed to Standard 59

**OPTIONS**

- Custom panels (powder coated metal, laminate, stainless steel, etc.)
- Custom tops (corian, granite, etc.)
- Black vinyl bumper
- Custom graphics
- Cart cover

**ELECTRICAL REQUIREMENTS**

- 120 Volt / 1 Phase / 20 Amp

**NOTE: Water system does not provide water for human consumption.**

**CUSTOM SINK CART**

*3', Three Compartment Cart*

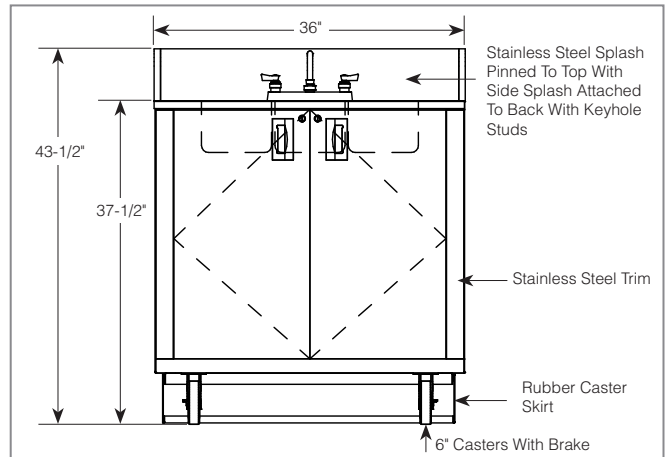
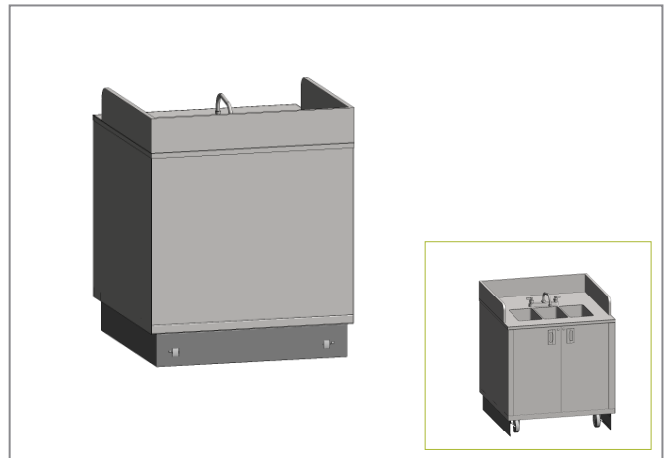

All fixtures and equipment to be connected to a single load center. Cart to have one (1) 8' power cable with a NEMA 5-20P plug.

**PLUMBING NOTES**

- One (1) 5-1/2 gallon fresh water tote tank
- One (1) 7-1/2 gallon waste water tote tank
- One (1) water pump
- One (1) 2-1/2 gallon hot water heater
- One (1) 2-compartment stainless steel hand sink with two (2) 6-1/8" x 12-1/8" x 5" deep bowls

Fresh and waste water tanks to be accessible from operator side and are removable with quick disconnects for ease of cleaning.

Water heater to deliver water to hand sink between a minimum of 80°F and a maximum of 120°F.

**GENERAL INFORMATION**

**Project Name:** \_\_\_\_\_  
**Item:** \_\_\_\_\_  
**Quantity:** \_\_\_\_\_  
**Model:** CUSTOM INFORMATION CART  
**Length:** \_\_\_\_\_

**STANDARD FEATURES**

- 16 gauge #304 stainless steel countertop
- 18 gauge #304 stainless steel trim
- 6" casters, two (2) rigid and two (2) swivel with brakes
- Black rubber caster skirt on three (3) sides
- Black vinyl bumper on three (3) sides
- Stainless steel exterior with vinyl graphics
- Stainless steel round retractable awning poles
- Open storage compartment with fixed program shelf
- A-Frame powder coated header (red, blue or yellow)
- All tanks, valves, piping and fittings to comply with all NSF, local, state and federal health codes and standards
- U.L. Listed
- NSF Listed to Standard 59

**OPTIONS**

- Vinyl bumper colors
- Square awning poles
- Fixed awning poles
- Custom header / awning configurations
- Custom exterior panels (laminare, stainless steel, powder coat, etc.)
- Custom colors
- Custom graphics
- Metal cash drawer
- Lights
- Cart cover

**CUSTOM INFORMATION CART**

*Program / Information Cart*

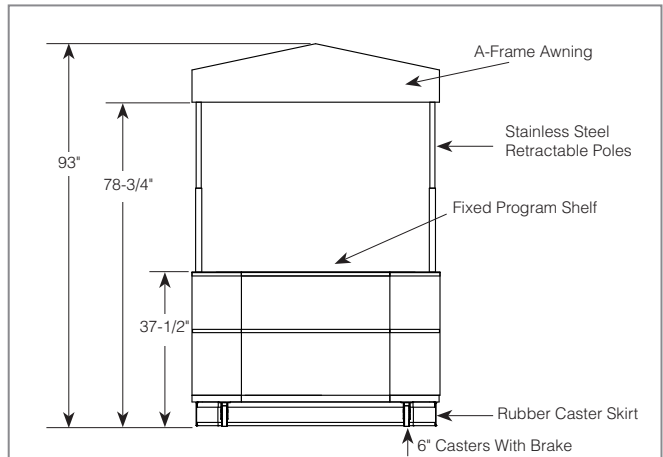
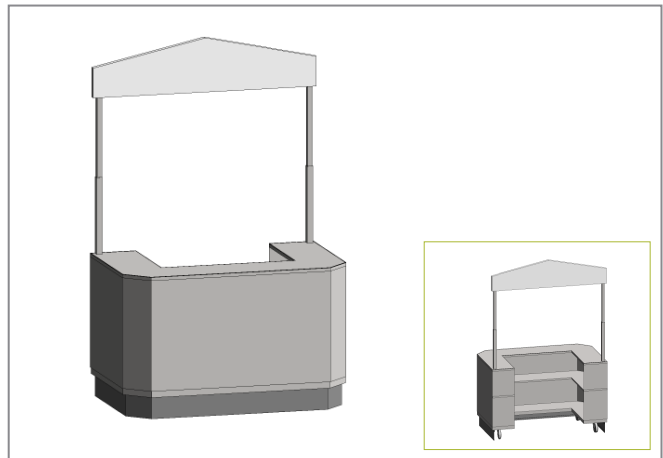

**GENERAL INFORMATION**

**Project Name:** \_\_\_\_\_  
**Item:** \_\_\_\_\_  
**Quantity:** \_\_\_\_\_  
**Model:** CUSTOM CASH CART  
**Length:** \_\_\_\_\_

**STANDARD FEATURES**

- 16 gauge #304 stainless steel countertop
- 18 gauge #304 stainless steel trim
- 6" casters, two (2) rigid and two (2) swivel with brakes
- Black rubber caster skirt on three (3) sides
- Stainless steel exterior panels
- Locking storage compartment
- Stainless steel shroud
- U.L. Listed
- NSF Listed to Standard 59

**OPTIONS**

- Custom panels (powder coated metal, laminate, stainless steel, etc.)
- Custom tops (corian, granite, etc.)
- Black vinyl bumper
- Custom graphics
- Cart cover

**EQUIPMENT SUPPLIED BY OTHERS**

- P.O.S. Station

**ELECTRICAL REQUIREMENTS**

- 120 Volt / 1 Phase / 20 Amp

**CUSTOM CASH CART**  
3' Cart

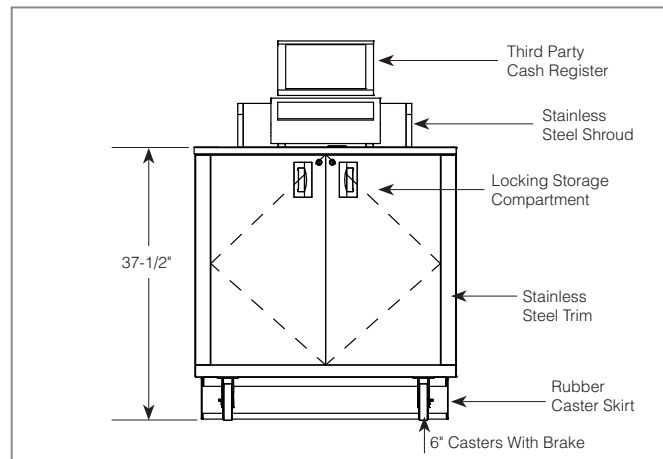
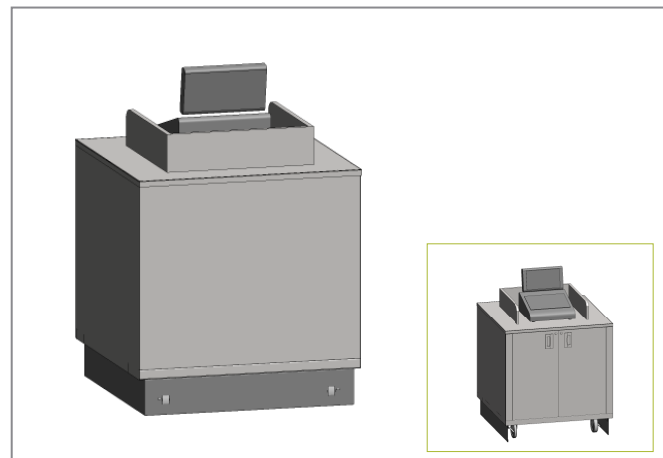

All fixtures and equipment to be connected to a single load center. Cart to have one (1) 8' power cable with a NEMA 5-20P plug.



**GENERAL INFORMATION**

**Project Name:** \_\_\_\_\_  
**Item:** \_\_\_\_\_  
**Quantity:** \_\_\_\_\_  
**Model:** CUSTOM NACHO CART  
**Length:** \_\_\_\_\_

**STANDARD FEATURES**

- 16 gauge #304 stainless steel countertop
- 18 gauge #304 stainless steel trim
- 6" casters, two (2) rigid and two (2) swivel with brakes
- Black rubber caster skirt on three (3) sides
- Powder coated exterior panels (red, blue or yellow)
- Hand sink with removable water tanks
- Locking tray slide compartments
- Locking storage compartment
- Stainless steel - glass food guard
- Stainless steel round retractable awning poles
- A-Frame awning with fabric covering (red, blue or yellow)
- All tanks, valves, piping and fittings to comply with all NSF, local, state and federal health codes and standards
- U.L. Listed
- NSF Listed to Standard 59

**OPTIONS**

- Vinyl bumper
- Square awning poles
- Fixed awning poles
- Drop shelf
- Round awning
- Custom exterior panels (laminated, stainless steel, powder coat, etc.)
- Custom colors
- Custom graphics
- Menu board
- Track lights
- Cart cover

**EQUIPMENT SUPPLIED**

- Nacho chip display case
- 2-Pan hot food well

**ELECTRICAL REQUIREMENTS**

- 120/208 Volt / 1 Phase / 30 Amp

**CUSTOM NACHO CART**

8' Cart

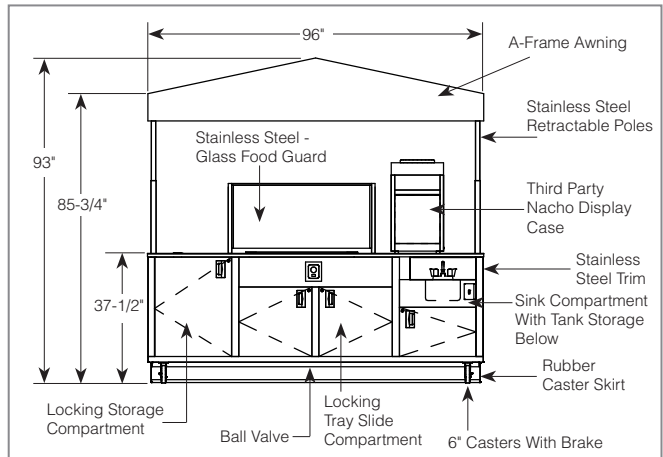
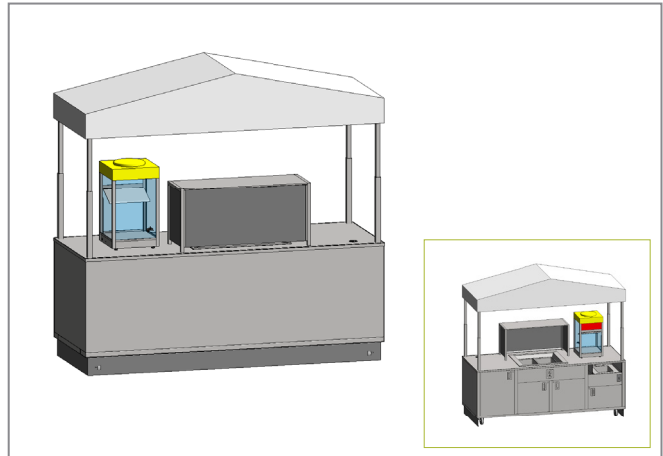

All fixtures and equipment to be connected to a single load center. Cart to have one (1) 8' power cable with a NEMA 14-30P plug.

**PLUMBING NOTES**

- One (1) 5-1/2 gallon fresh water tote tank
- One (1) 7-1/2 gallon waste water tote tank
- One (1) water pump
- One (1) 2-1/2 gallon hot water heater
- One (1) 2-compartment stainless steel hand sink with two (2) 6-1/8" x 12-1/8" x 5" deep bowls

Fresh and waste water tanks to be accessible from operator side and are removable with quick disconnects for ease of cleaning.

Water heater to deliver water to hand sink between a minimum of 80°F and a maximum of 120°F.

2-Pan hot food well to drain to individual ball valves located below the cart.

**GENERAL INFORMATION**

**Project Name:** \_\_\_\_\_  
**Item:** \_\_\_\_\_  
**Quantity:** \_\_\_\_\_  
**Model:** CUSTOM POPCORN CART  
**Length:** \_\_\_\_\_

**STANDARD FEATURES**

- 16 gauge #304 stainless steel countertop
- 18 gauge #304 stainless steel trim
- 6" casters, two (2) rigid and two (2) swivel with brakes
- Black rubber caster skirt on three (3) sides
- Powder coated exterior panels (red, blue or yellow)
- Hand sink with removable water tanks
- Locking storage compartment
- Stainless steel round retractable awning poles
- A-Frame awning with fabric covering (red, blue or yellow)
- All tanks, valves, piping and fittings to comply with all NSF, local, state and federal health codes and standards
- U.L. Listed
- NSF Listed to Standard 59

**OPTIONS**

- Vinyl bumper
- Square awning poles
- Fixed awning poles
- Drop shelf
- Round awning
- Custom exterior panels (laminates, stainless steel, powder coat, etc.)
- Custom colors
- Custom graphics
- Menu board
- Track lights
- Cart cover

**EQUIPMENT SUPPLIED**

- Popcorn popper

**ELECTRICAL REQUIREMENTS**

- 120/208 Volt / 1 Phase / 30 Amp

**CUSTOM POPCORN CART**

8' Cart

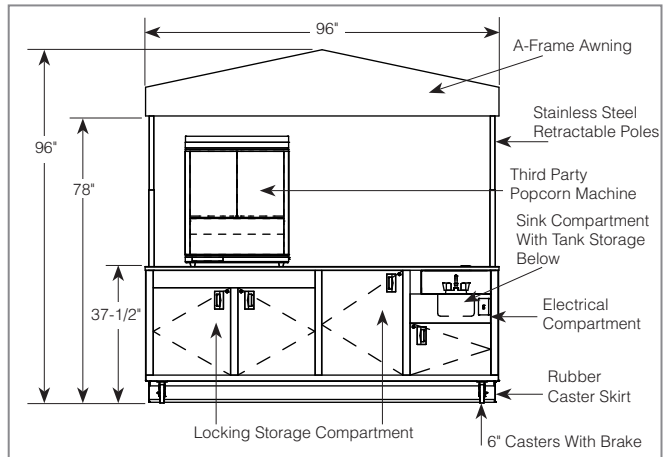
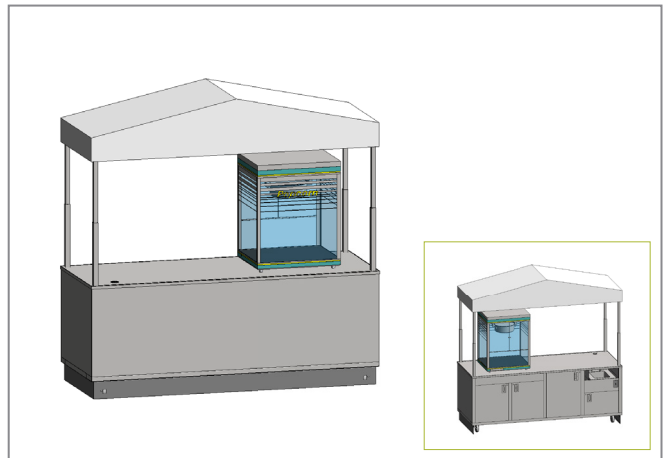

All fixtures and equipment to be connected to a single load center. Cart to have one (1) 8' power cable with a NEMA 14-30P plug.

**PLUMBING PROVIDED**

- One (1) 5-1/2 gallon fresh water tote tank
- One (1) 7-1/2 gallon waste water tote tank
- One (1) water pump
- One (1) 2-1/2 gallon hot water heater
- One (1) 2-compartment stainless steel hand sink with two (2) 6-1/8" x 12-1/8" x 5" deep bowls

Fresh and waste water tanks to be accessible from operator side and are removable with quick disconnects for ease of cleaning.

Water heater to deliver water to hand sink between a minimum of 80°F and a maximum of 120°F.

**GENERAL INFORMATION**

**Project Name:** \_\_\_\_\_  
**Item:** \_\_\_\_\_  
**Quantity:** \_\_\_\_\_  
**Model:** CUSTOM COLD FOOD CART  
**Length:** \_\_\_\_\_

**STANDARD FEATURES**

- Laminate countertop with t-mold edges
- Mahogany stained body
- Mahogany stained trim
- Mahogany stained push handles
- 32" diameter hardwood spoke wheels
- 6" swivel caster with brake
- Mahogany stained caster support with metal support
- Drop-in 2-pan cold food well
- Locking storage compartment (both ends)
- Mahogany stained awning posts
- A-frame awning with Sunbrella covering
- U.L. Listed
- NSF Listed to Standard 59

**OPTIONS**

- Drop shelf
- Round awning
- Custom colors
- Custom graphics
- Menu board
- Track lights
- Cart cover
- Portable waste tank

**ELECTRICAL REQUIREMENTS**

- 120 Volt / 1 Phase / 15 Amp

**CUSTOM COLD FOOD CART**

*5' Wood Merchandise Cart*

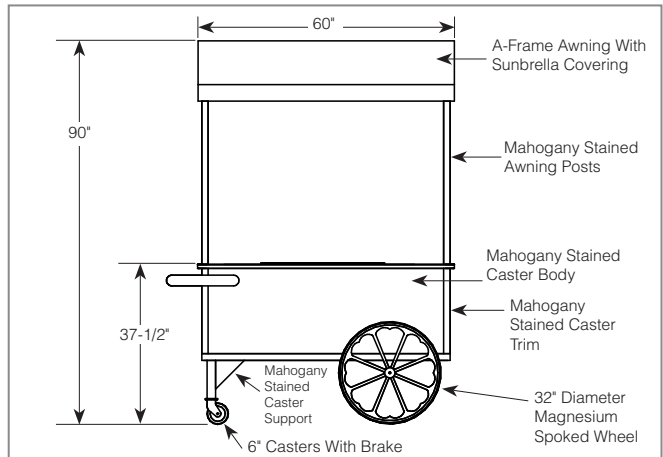
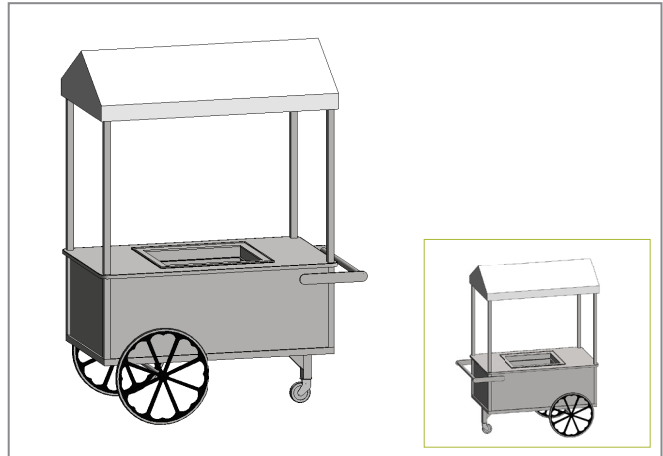

All fixtures and equipment to be connected to a single load center. Cart to have one (1) 8' power cable with a NEMA 5-15P plug.

**GENERAL INFORMATION**

**Project Name:** \_\_\_\_\_  
**Item:** \_\_\_\_\_  
**Quantity:** \_\_\_\_\_  
**Model:** CUSTOM COLD FOOD CART  
**Length:** \_\_\_\_\_

**STANDARD FEATURES**

- Laminate countertop with t-mold edges
- Mahogany stained body
- Mahogany stained trim
- Mahogany stained push handles
- 32" diameter hardwood spoke wheels
- 6" swivel caster with brake
- Mahogany stained caster support with metal support
- Drop-in cold food well (4-pan)
- Locking storage compartment (both ends)
- Mahogany stained awning posts
- A-frame awning with Sunbrella covering
- U.L. Listed
- NSF Listed to Standard 59

**OPTIONS**

- Drop shelf
- Round awning
- Custom colors
- Custom graphics
- Menu board
- Track lights
- Cart cover
- Portable waste tank

**ELECTRICAL REQUIREMENTS**

- 120 Volt / 1 Phase / 15 Amp

**CUSTOM COLD FOOD CART**

*7' Wood Merchandise Cart*

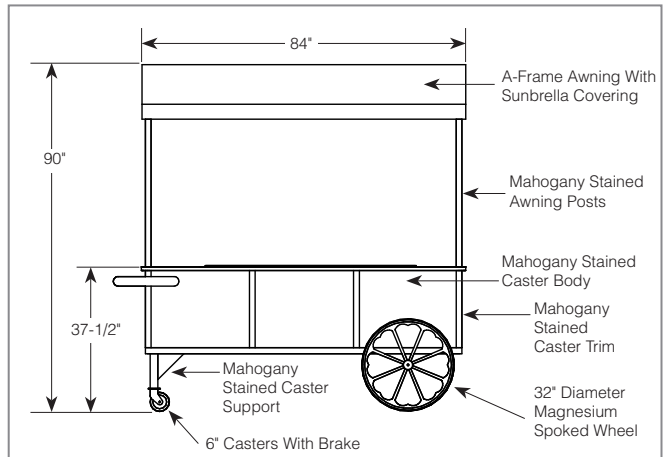

All fixtures and equipment to be connected to a single load center. Cart to have one (1) 8' power cable with a NEMA 5-15P plug.

**GENERAL INFORMATION**

**Project Name:** \_\_\_\_\_  
**Item:** \_\_\_\_\_  
**Quantity:** \_\_\_\_\_  
**Model:** CUSTOM HOT FOOD CART  
**Length:** \_\_\_\_\_

**STANDARD FEATURES**

- Laminate countertop with t-mold edges
- Mahogany stained body
- Mahogany stained trim
- Mahogany stained push handles
- 32" diameter hardwood spoke wheels
- 6" swivel caster with brake
- Mahogany stained caster support with metal support
- Two (2) drop-in 2-pan hot food wells with individual controls, drains and indicator lights
- Locking storage compartment (both ends)
- Mahogany stained awning posts
- A-frame awning with Sunbrella covering
- U.L. Listed
- NSF Listed to Standard 59

**OPTIONS**

- Drop shelf
- Round awning
- Custom colors
- Custom graphics
- Menu board
- Track lights
- Cart cover
- Portable waste tank

**ELECTRICAL REQUIREMENTS**

- 120/208 Volt / 1 Phase / 30 Amp

**CUSTOM HOT FOOD CART**

*7' Wood Merchandise Cart*

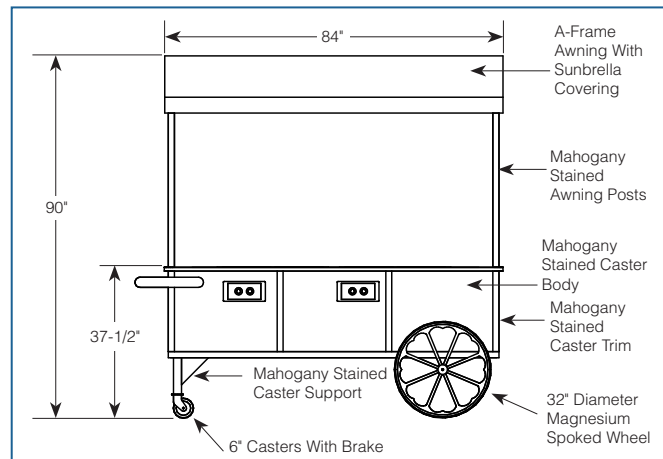
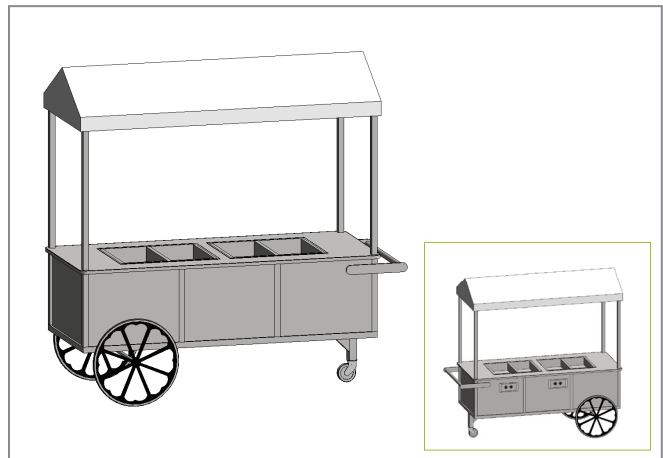

All fixtures and equipment to be connected to a single load center. Cart to have one (1) 8' power cable with a NEMA 14-30P plug.

**PLUMBING NOTES**

The hot wells drain to an individual ball valve located below the cart.

**GENERAL INFORMATION**

**Project Name:** \_\_\_\_\_  
**Item:** \_\_\_\_\_  
**Quantity:** \_\_\_\_\_  
**Model:** CUSTOM COLD/HOT FOOD CART  
**Length:** \_\_\_\_\_

**STANDARD FEATURES**

- Laminate countertop with t-mold edges
- Mahogany stained body
- Mahogany stained trim
- Mahogany stained push handles
- 32" diameter hardwood spoke wheels
- 6" swivel caster with brake
- Mahogany stained caster support with metal support
- Drop-in 2-pan hot food wells with individual controls, drains and indicator lights
- Locking storage compartment (both ends)
- Mahogany stained awning posts
- A-frame awning with Sunbrella covering
- U.L. Listed
- NSF Listed to Standard 59

**OPTIONS**

- Drop shelf
- Round awning
- Custom colors
- Custom graphics
- Menu board
- Track lights
- Cart cover
- Portable waste tank

**ELECTRICAL REQUIREMENTS**

- 120/208 Volt / 1 Phase / 30 Amp

**CUSTOM COLD/HOT FOOD CART**

*7' Wood Merchandise Cart*

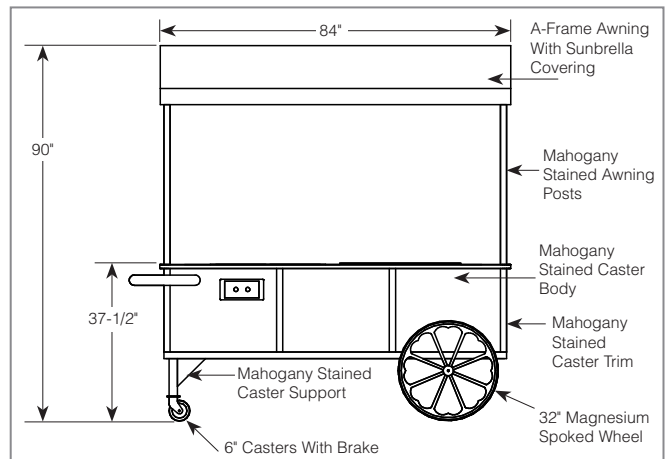
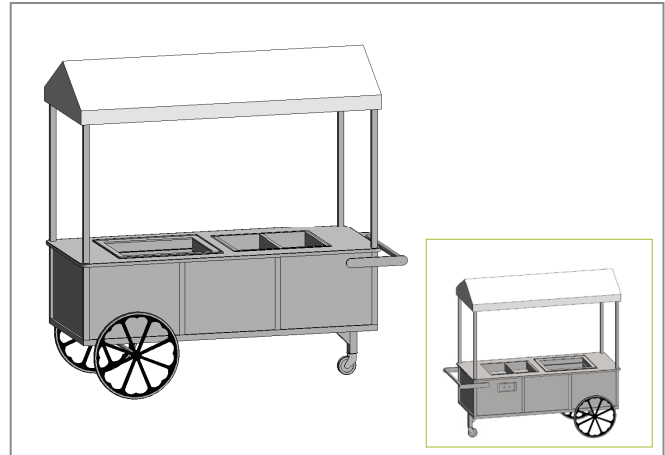

All fixtures and equipment to be connected to a single load center. Cart to have one (1) 8' power cable with a NEMA 14-30P plug.

**PLUMBING NOTES**

The hot wells drain to an individual ball valve located below the cart.

All carts and kiosks can be custom however not every option will fit every cart. Confirm with factory on all additional options or construction changes.

**AWNING OPTIONS**

- Square awning poles
- Retractable awning poles
- A-frame awning
- Round awning
- Custom awning configurations
- Custom Color/Art

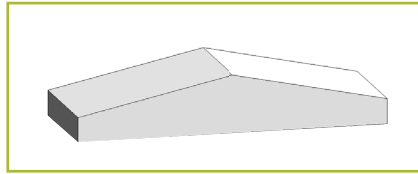

A-Frame Awning

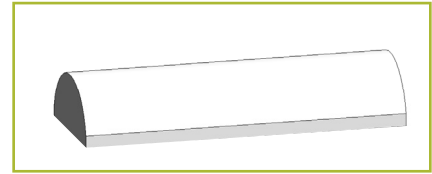

Round Awning

**BUYOUT OPTIONS**

- Refrigerator
- Sink/Faucet
- Beverage Dispenser
- Condiment Dispenser
- Cold Pan
- Hot Pan
- Other

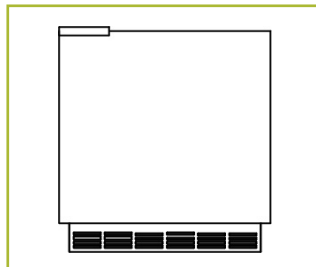

Refrigerator

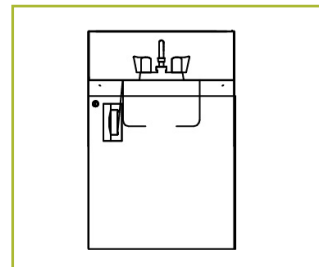

Sink/Faucet

**DECORATIVE OPTIONS**

- Custom graphics
- Custom colors
- Track lights
- Vinyl bumper colors
- Menu board
- Cart cover
- Other

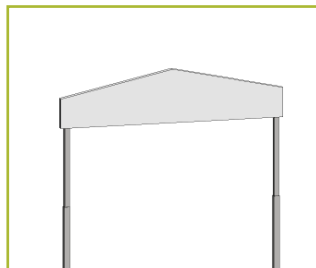

Menu Board

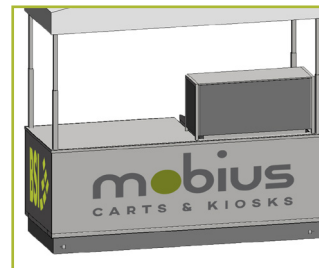

Custom Graphics

**CONSTRUCTION OPTIONS**

- Custom exterior panels (laminated, stainless steel, powder coat, etc.)
- Food Guard
- Drop shelf
- Custom tops (corian, granite, etc.)
- Open storage
- Closed storage
- Lockable storage
- Other

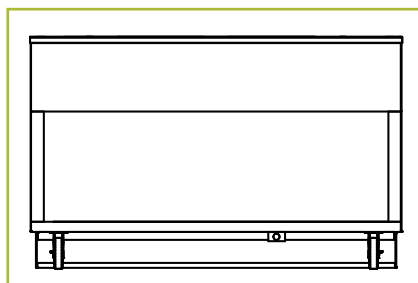

Open Storage

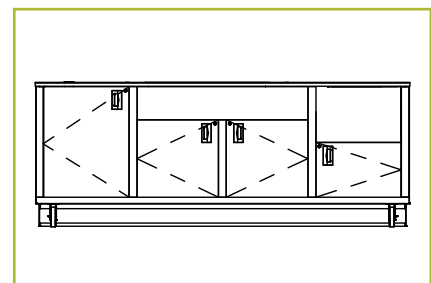

Storage Configurations