



OWNER'S MANUAL & WARRANTY

ZGUARD FOOD SHIELDS

LIGHTS & WARMERS

Thank you for choosing products from BSI. We appreciate your business and are available to assist you with all of your needs.

This manual has been designed to help you better understand your product and its proper usage.

If you have questions that go beyond this detailed manual please contact our Customer Service Department at 1.800.662.9595.

**Thank you,
The BSI Team**

The distinctive and original product design of ZGuard food shield shown above is protected trade dress owned by BSI, LLC, and may not be used without permission.

TABLE OF CONTENTS

Contents	3	<i>Lights and Warmers</i>	
Introduction	3	Safety Precautions	16
Important Owner Information	3	Receiving and Inspecting the Equipment	16
Safety Precautions	4	Models	16
Receiving and Inspecting the Equipment	4	Maintenance and Fixtures	17
		Service and Ordering Parts	18-19
ZGuard Food Shields		Wiring Installations	20-21
Models	4-5	Wiring Diagrams	22-23
Basic Components and Layout	6		
ZGuard Bracket	7	Warranty	24
Bracket Mechanism	8		
Glass Management	8		
ZG9600 Assembly	9		
End Panels	10		
ZGuard Installation Options	11-13		
ZGuard Accessories - ZSpace	14		

The BSI, LLC manual is an important part of your equipment. This document should be stored in a safe location, as it will be useful for the life of your product. It contains important safety information concerning the maintenance, operation and servicing of these products.

Failure to properly use this manual may result in serious injury. Do not operate this equipment unless you have read and understood the contents of this manual.

IMPORTANT OWNER INFORMATION

Record the model number(s) of your ZGuard and serial number(s), of your warming units to use as a reference when contacting your local representative or the BSI headquarters in Colorado.

Model No.:	
Serial No.:	
Model No.:	
Serial No.:	
Date of Purchase:	
Other:	

BSI, LLC
 Business Hours: 8:00 a.m. to 4:30 p.m.
 Mountain Time

Telephone: (800) 662-9595; (303) 331-8777
 Fax: (303) 331-8444

Web Address: www.BSIdesigns.com

SAFETY PRECAUTIONS



The ZGuard Food Shield must be installed in accordance with the applicable installation code by a person familiar with the construction and operation of the product and the hazards involved.

RECEIVING AND INSPECTING THE EQUIPMENT

Even though most equipment is shipped crated, care should be taken during unloading so the equipment is not damaged while being moved into your facility.

1. Visually inspect the exterior of the package and skid or container. Any damage should be noted and reported to the delivering carrier immediately.
2. If damaged, open and inspect the contents with the carrier.
3. In the event that the exterior is not damaged, yet, upon opening, there is concealed damage to the equipment, notify the carrier. Notification should be made verbally as well as in written form.
4. Request an inspection by the shipping company of the damaged equipment. This should be done within 10 days from receipt of the equipment.
5. Be sure to check that there is no broken glass.
6. Be sure to check that all materials are received.
7. Freight carriers can supply the necessary damage forms upon request.
8. Retain all crating materials until an inspection has been made or waived.
9. All ZGuard packages contain drawings for your installer.
10. All ZGuard packages contain this Owner's Manual and Warranty.

ZGUARD MODELS

ZGuard food shields are manufactured in many different configurations. While the components are all similar, your model's glass and posts may not be. Post will either be aluminum or stainless steel. The models shown below and on the following page should be maintained in the same manner based on the instructions within this manual.

If you have questions regarding a ZGuard or are interested in custom configurations please contact BSI, LLC at 1.800.662.8777.



ZG7500



ZG7500-2



ZG7600



ZG7700



ZG7930



ZG7930-2



ZG7950



ZG9500

All ZGuard models are certified by NSF.



ZGUARD MODELS



ZG9500-2



ZG9500-3



ZG9500-4



ZG9500-5



ZG9500-6



ZG9560



ZG9560-2



ZG9600



ZG9900



ZG9915



ZG9930



ZG9930-2



ZG9930-3



ZG9930-5



ZG9945



ZG9945-3



ZG9945-4



ZG9945-5



ZG9950



ZG9950-2

BASIC COMPONENTS & LAYOUT

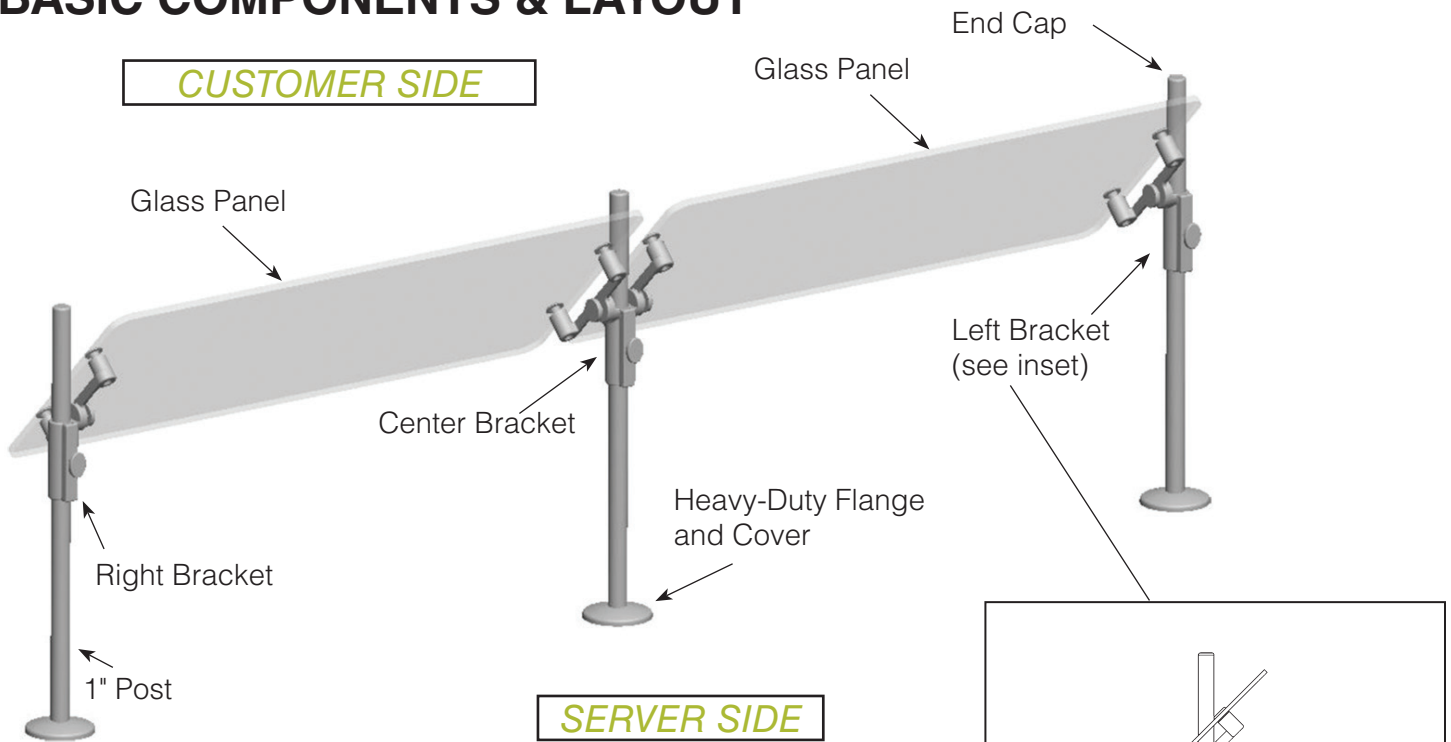

Fig. 1 shows a two-panel ZG9500 with a center bracket. Center bracket may be substituted with a stacked left/right bracket combination for a different configuration.

Fig. 2 shows section view of Fig. 1.

ZGUARD BRACKETS



Left Bracket Assembly



Center Bracket Assembly



Right Bracket Assembly

SEE EXPLODED VIEW AND PART NUMBERS ON PAGE 7.

ZGUARD BRACKET ASSEMBLY AND PARTS

Full Assembly

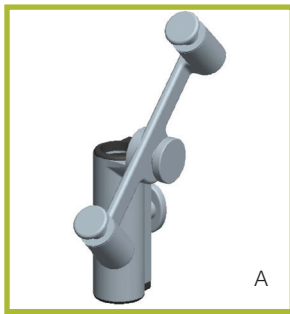

Clamp Section Only

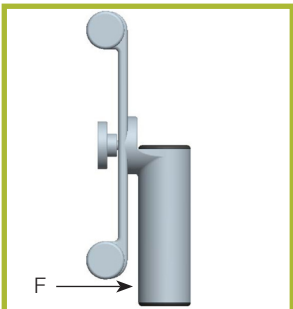
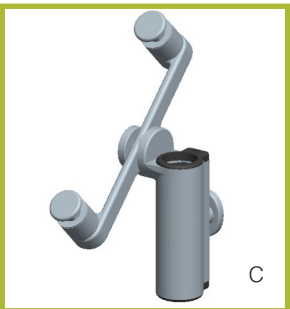
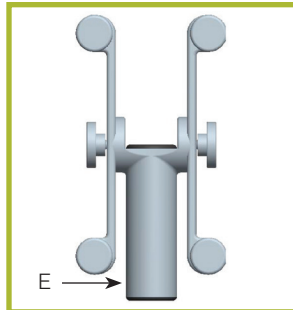
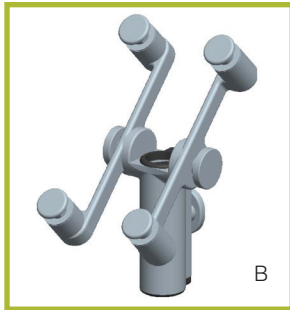
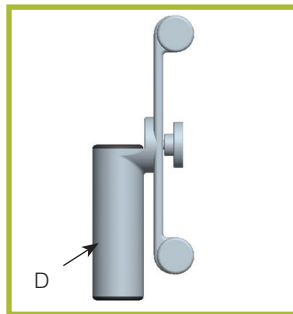

Half Arm Assembly

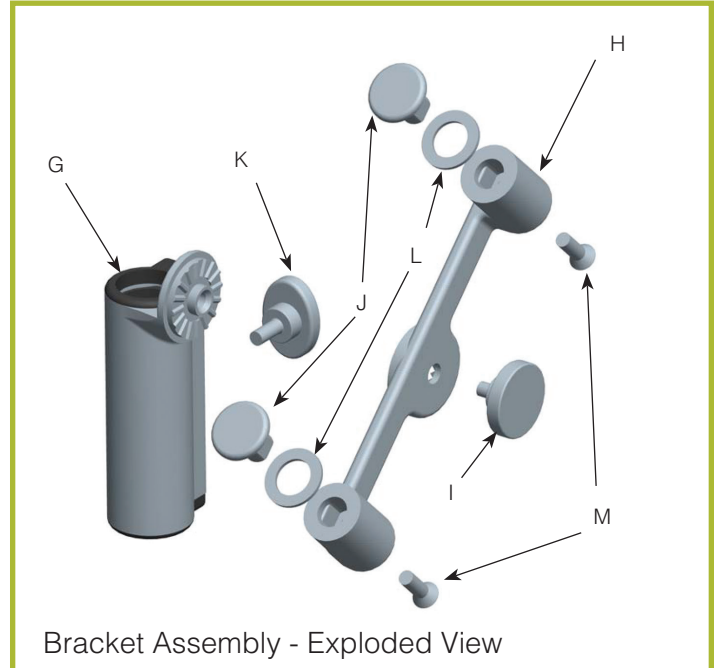
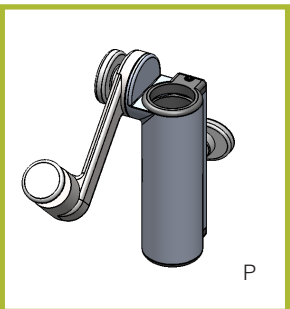
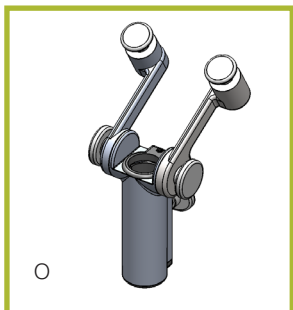
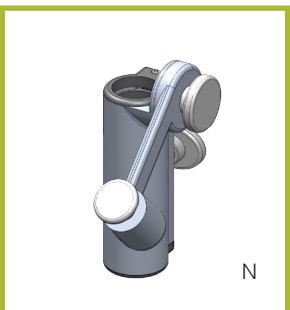

Location	Part #	Part Name
A	553	Left Bracket Assembly
B	554	Center Bracket Assembly
C	555	Right Bracket Assembly
D	322	Left Post Clamp
E	424	Center Post Clamp
F	323	Right Post Clamp
G	324	Post Clamp Insert
H	321	Glass Mounting Clamp
I	326	Round Knob
J	336	Decorative Nut
K	457	Oval Knob
L	484	Clear Mylar Spacer
M		1/4-20 x 1-1/4" Machine Screw Flat Philips
N	553RX	Left Bracket Right Half Arm Assy.
O	554X	Center Bracket Half Arm Assembly
P	555LX	Right Bracket Left Half Arm Assy.

* When ordering you **MUST** designate finish/color.

In the event that your ZGuard product needs service and requires major repairs, contact your local installer for assistance.

If you have questions about the products or need to replace minor parts you may contact BSI, LLC at 1.800.662.9595.

GLASS AND BRACKET POSITION

The angle of the glass panels can be tilted forward or backwards in 22-1/2° increments. The panels (glass and bracket combination) can be raised or lowered by adjusting the brackets. As detailed in Figure #1 (page 6), the bracket's Oval Knob is on the Server Side (depending on food shield configuration, Oval Knob location may vary). The bracket's Round Knob, which holds the Glass Mounting Clamp in place, faces the food.

ZGUARD BRACKET ADJUSTMENT

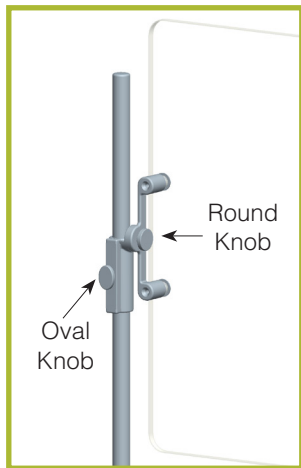

Illustration #1: Bracket and glass in 'Home' position.

ZGuard brackets allow you to adjust the food shield height and angle of glass.

Referred to as the 'home' position, bracket and glass will be in vertical position.

With the assistance from a second person, take the following steps to adjust your ZGuard.

1. To raise or lower the bracket, loosen the Oval Knob from the Post Clamp. Slide to new position and tighten. (See Illustration #1)
2. To adjust angle of the glass, loosen the Round Knob and then adjust the glass angle to desired location. (See Illustration #1)

CLEANING INSTRUCTIONS

Cleaning your new ZGuard product is key to its long life.

BSI recommends the following for keeping your product clean:

- Wipe the surface with a clean, damp cloth to remove fingerprints, dust, etc.
- Spray with a light coating of glass cleaner to remove grease or other dirt. Use a non-ammonia cleaner.
- Do not polish ZGuard with any brass polish. Your ZGuard has a durable finish and will maintain its finish for years if well maintained. (Polishing the finish with a polishing agent of any kind will destroy the coating.)
- Do not scrub the surface with any abrasive substance such as steel wool, pot scrubbers, Ajax cleanser, Comet or similar products, as it will remove the protective coating.
- If unit is fitted with a stealth warmer, don't clean the glass or housing fixtures when warmer is hot. **Cleaning when over head warmer is hot can cause staining or damage to food warmer finish.**



GLASS LIMITATIONS

ZGuard food shield systems that are equipped with a shelf are not intended to withstand heavy weights. Glass shelves can certainly hold small display items.

RECOMMENDATIONS

Do not exceed **75lbs.** total weight of all display items across a three-foot panel of 3/8" thick glass.

TESTING PARAMETERS

Food Shield:	ZG9500 (glass panel positioned at 90° to post)
Posts & Brackets:	Brushed Aluminum
Glass:	36" x 14" (3/8" thick)
Mounting:	Above Counter
Time:	24 hours

ZGUARD ZG9600 ASSEMBLY

ZG9600 Assembly Instructions

1. From the underside, use the provided screws to attach the stabilizer to each foot. There are two alternate locations for stabilizer placement.
2. Right side up, screw in the two posts.
3. In the non-used post holes screw in the provided foot plugs.
4. Affix the glass panel to the left and right bracket assemblies.
5. Slide the brackets onto the left and right post. At level height tighten bracket for secure hold.
6. With the brackets parallel to the counter, screw the glass panel to the brackets.
7. Adjust glass angle and height as needed.

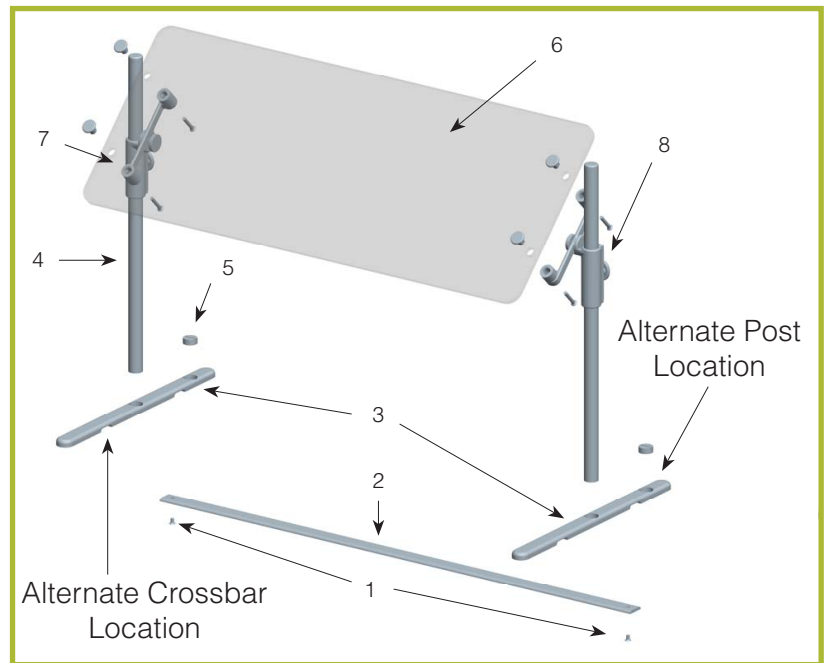

Location	Part #	Part Name
1		Market Stabilizer Screw
2	415	Market Stabilizer
3	416	Market Style Foot
4	348	Post
5	361	Foot Plug
6		Glass Panel
7	553	Left Bracket Assembly
8	555	Right Bracket Assembly



NSF REQUIRED END PANELS FOR ZGUARD

To meet NSF guidelines, end panels are included on all BSI quotations unless specifically excluded.

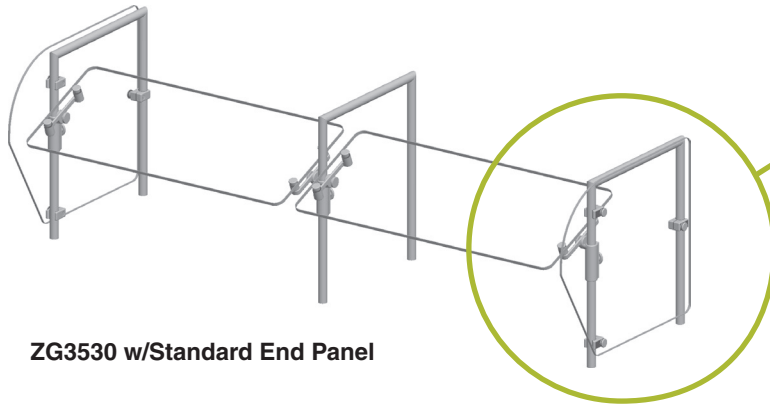

ZG3530 w/Standard End Panel

Location	Part #	Part Name
9	336	Decorative Nut
10	484	Clear Mylar Spacer
11	15756	End Panel Bracket Assembly
12		1/4-20 x 1-1/4" Machine Screw Flat Philips

NSF End Panel Requirement Exemption

NSF/ANSI Standard 2 - 2018

5.36.1.6.2 A food shield intended to be installed a maximum of 3 in (76 mm) from a building wall perpendicular to the food shield is exempt from the requirements of 5.36.1.6.1 provided that the height of the building wall is not lower than the overall height of the food shield. The manufacturer's specification sheet, brochure, installation instructions and/or shop drawings shall include these building wall and proximity requirements.

ABOVE-COUNTER INSTALLATION FOR 1" ZGUARD POSTS

For Stainless Steel Counter
SS1: EZ Mount 2" x 8" Flange

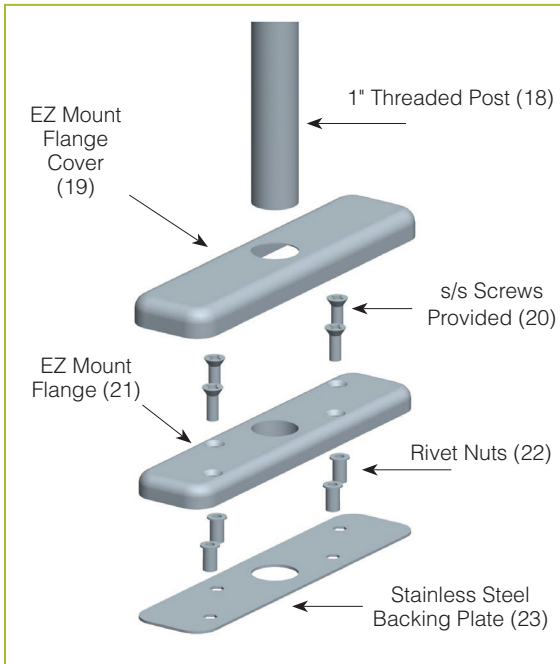

Location	Part #	Part Name
18	348	1" Threaded Post
19	485	EZ Mount Center Flange Cover
20		10-32 x 1" S/S Screw Flat Phillips
21	470	EZ Mount Base Flange Centered
22		Rivet Nut
23	473	EZ Mount Flange Plate Centered
24	464	Heavy-Duty Flange Cover
25		#12 x 2 A Tapping Screw Flap Phillips
26	471	Heavy-Duty Flange
27	465	Narrow Flange Cover
28	378	Narrow Flange
29	442	Grommet

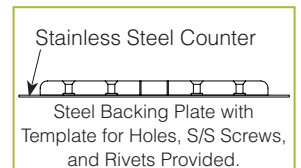
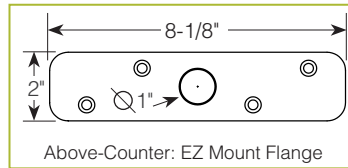

For Millwork Counter
MW1: Heavy Duty Flange

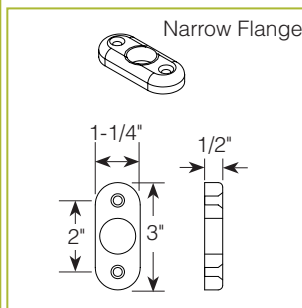
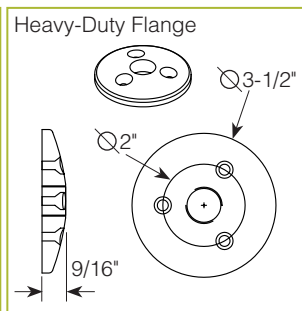
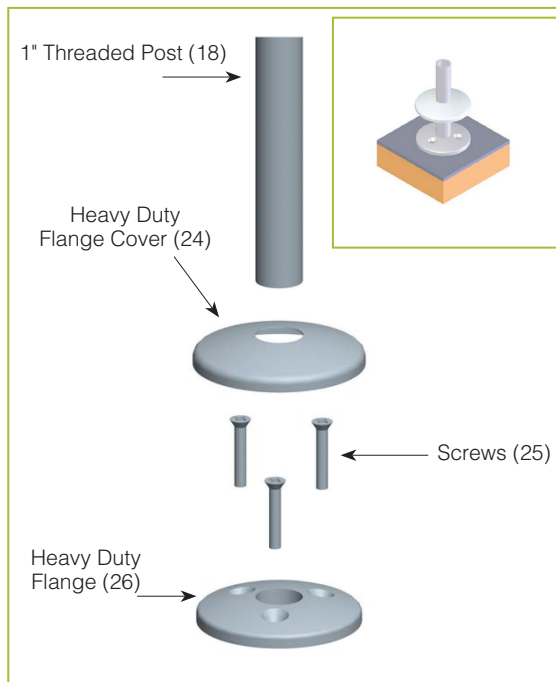

For Millwork Counter
MW2: Narrow Flange

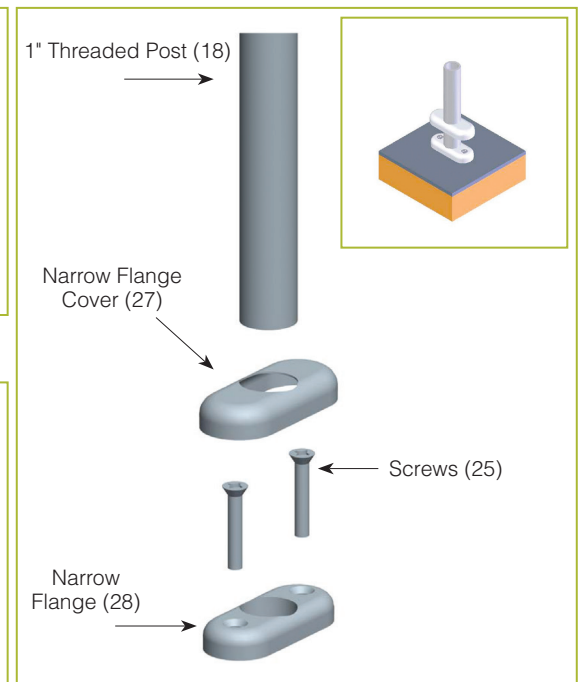

UNDER-COUNTER INSTALLATION FOR 1" ZGUARD POSTS

For Stainless Steel Counter
 (requires under-counter reinforcement and access)
SSU3: Heavy Duty Flange (-H) or Narrow Flange (-N)

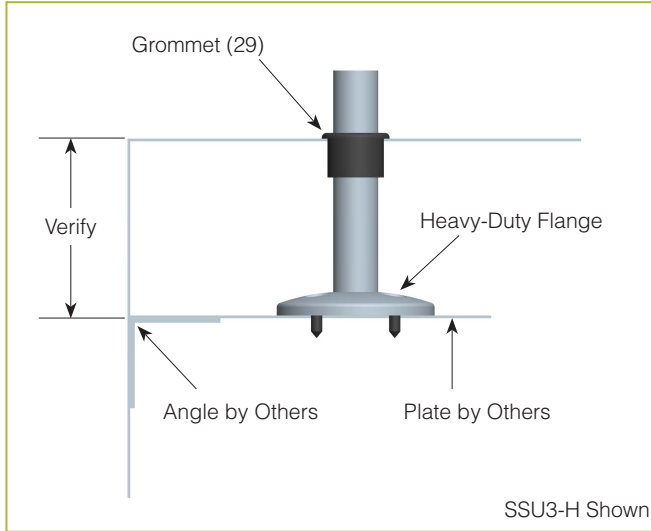

For Stainless Steel Counter
 (requires under-counter reinforcement and access)
SSU5: Heavy Duty Flange (-H) or Narrow Flange (-N)

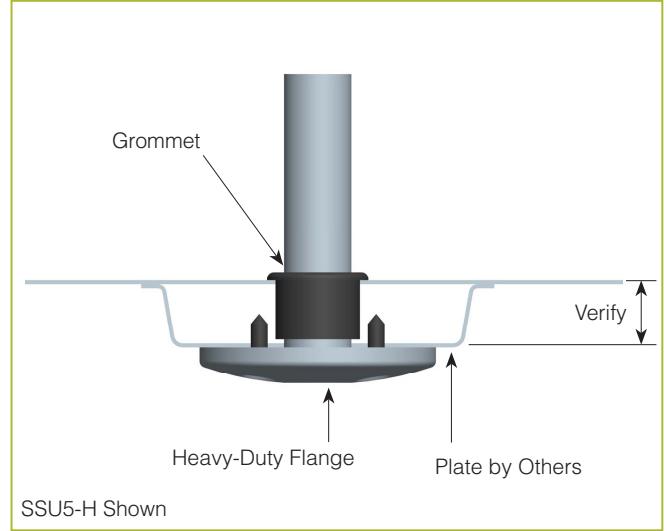

Verify Counter Thickness or Under-Counter Installation Depth in Inches

For Millwork Counter
MWU3: Narrow Flange

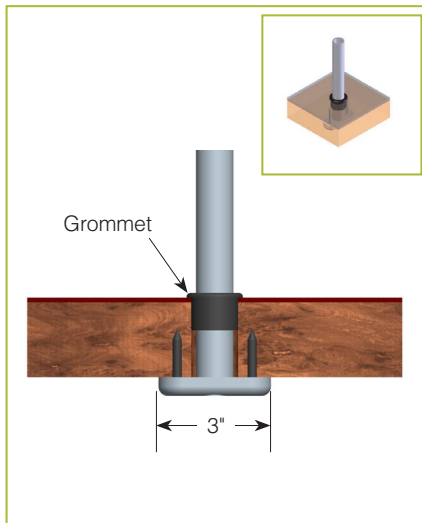

For Millwork Counter
MWU4: Compression Installation
 (not recommended for solid surfaces)

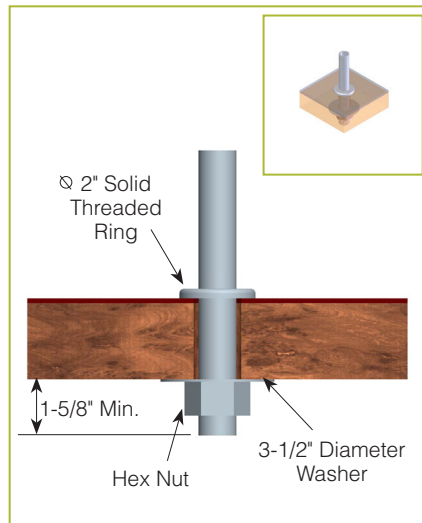

For Millwork Counter
MWU5: Heavy Duty Flange

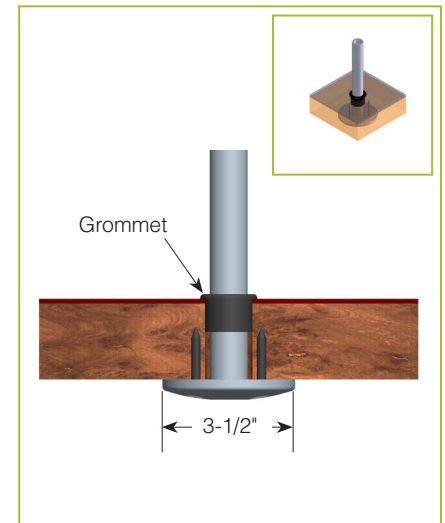

Verify Counter Thickness or Under-Counter Installation Depth in Inches

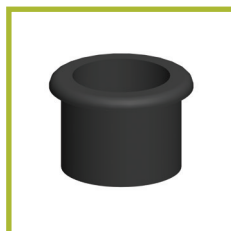

For below-counter installation a 1-1/4" diameter grommet is required. (Part #442)

➤ ABOVE-COUNTER INSTALLATION FOR 1-1/2" ZGUARD POSTS

**For Millwork Counter
Surface Installation 720A/726A:
Steel Post and Flange w/Flange Cover**

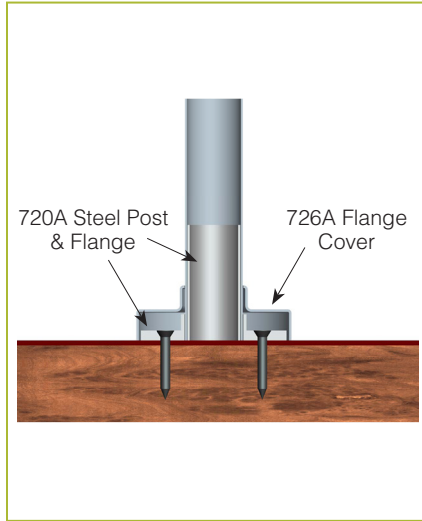

**For Millwork Counter
Surface Installation 725A:
Cut Flange**

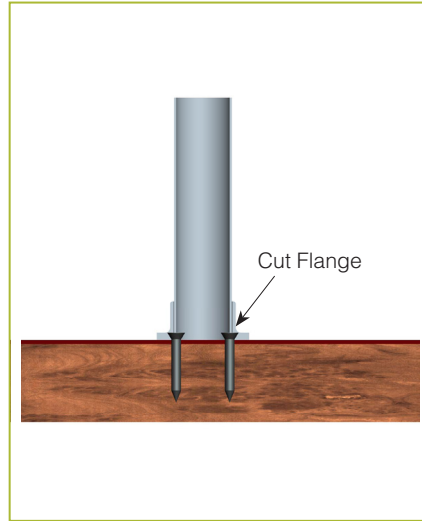

**For Millwork Counter
Concealed Fastener
(not for cantilever units)**

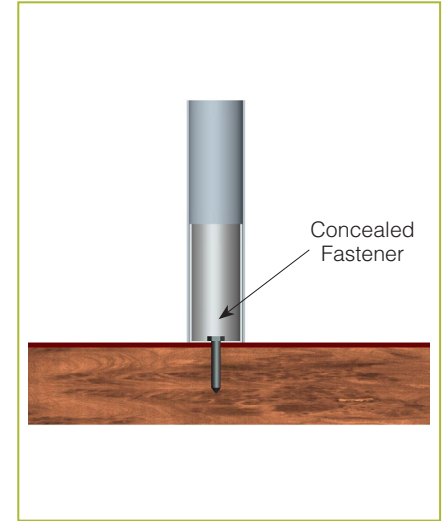

➤ UNDER-COUNTER INSTALLATION FOR 1-1/2" ZGUARD POSTS (requires under-counter reinforcement and access)

**Under-Counter Installation 720A/726A:
Steel Post and Flange w/Flange Cover**

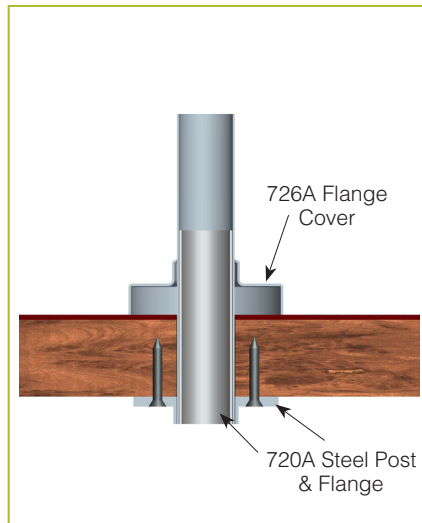

**Under-Counter Installation 720A:
Steel Post and Flange w/out Flange Cover**

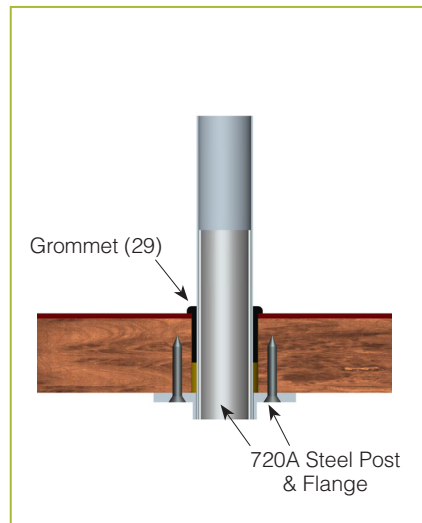

**Under-Counter Installation 725A:
Narrow Custom Flange**

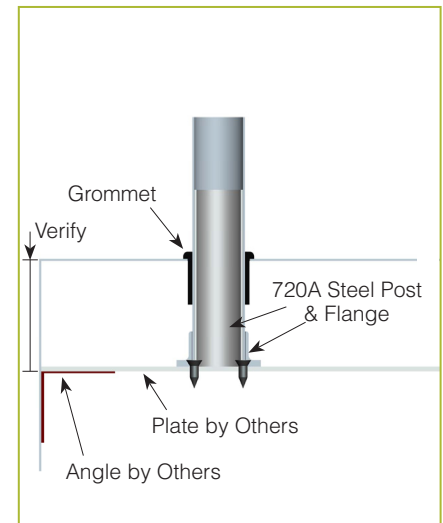

➤ FLANGE AND FLANGE COVER DIMENSIONS

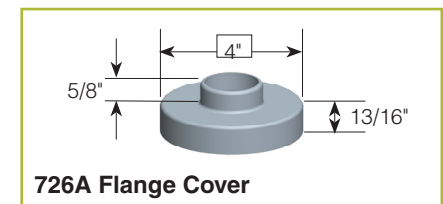
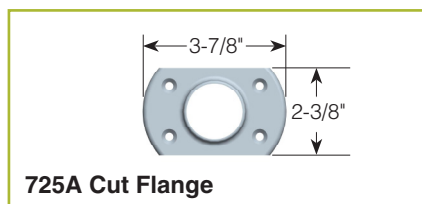
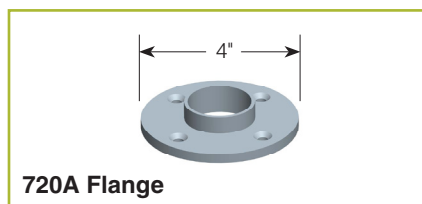

Once installed, ZGuard offers your servery additional merchandising solutions. BSI, LLC offers ZSpace modular merchandising products. ZSpace allows you to take advantage of every inch of your counters and the space above them. ZSpace offers innovative products ranging from trivets, trays and POP displays that attach to your existing food shields and offer sales/merchandising opportunities like never before.

ZSPACE COMPONENTS

Just install the incredible EZ-Clamp anywhere on your ZGuard food shield and add up to three Flexi-Rings. The rings can hold bowls, trivets, vases or any other container to create innovative merchandising displays.

ESSENTIALS



EZ-Clamp



Flexi-Ring

DISPLAY OPTIONS



Aluminum Tray



Acrylic Trivet

GET NOTICED



Post-Mounted Sign



Small Crescent Sign

ZSPACE KITS

BSI offers pre-chosen ZSpace Kits with suggested themes to help you save time. Nearly every combination can be created by you or with our help.



Large Salad Bar Display



Three-Tier Display

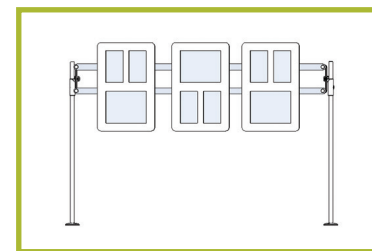

Menu Frames

Not all components shown.
For more information about our line of ZSpace Components and ZSpace Kits please contact us at 1.800.662.9595 or visit us at www.BSIdesigns.com.



OWNER'S MANUAL & WARRANTY

LIGHTS & WARMERS

LIGHTS & WARMERS

ZGuard food shield systems can be built with lights, warmers or a combination of the two. Proper maintenance for these products is very important for safety. The following pages will detail the proper methods of keeping your product clean, how and where to exchange parts, and include diagrams for proper wiring.

RECEIVING AND INSPECTING THE EQUIPMENT

Even though most equipment is shipped crated, care should be taken during unloading so the equipment is not damaged while being moved into your facility.

1. Visually inspect the exterior of the package and skid or container. Any damage should be noted and reported to the delivering carrier immediately.
2. If damaged, open and inspect the contents with the carrier.
3. In the event that the exterior is not damaged, yet, upon opening, there is concealed damage to the equipment, notify the carrier. Notification should be made verbally as well as in written form.
4. Request an inspection by the shipping company of the damaged equipment. This should be done within 10 days from receipt of the equipment.
5. Be sure to check that there is no broken glass.
6. Be sure to check that all materials are received.
7. Freight carriers can supply the necessary damage forms upon request.
8. Retain all crating materials until an inspection has been made or waived.
9. All packages contain drawings for your installer.
10. All Light and Warmer packages contain this Owner's Manual and Warranty.



ALL LIGHTS, WARMERS AND COMBO UNITS ARE SHIPPED USING ZIP TIES TO SECURE UNITS DURING TRANSIT. AFTER INSTALLATION, CAREFULLY REMOVE ALL ZIP TIES.



This product must be installed in accordance with the applicable installation code by a person familiar with the construction and operation of the product and the hazards involved.

All Light and Warmer models are certified by NSF.



MODELS

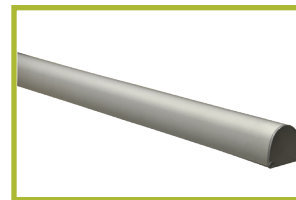

Slimline Light Model 2580

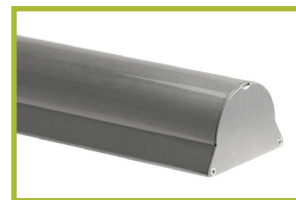

Stealth Warmer Model 490



Stealth Warmer & Light Combo Model 605



Stealth Double Warmer & Light Combo Model 500

CLEANING INSTRUCTIONS

Once your ZGuard has been properly installed and you have removed all zip ties from transportation, it will be important to keep your light, warmer or combo unit clean to prolong the life of the product.

BSI recommends the following for keeping your product clean:

- Be sure to turn the power on your light or warmer off before cleaning. Only clean when stealth warmer is cool. **Cleaning when the warmer is hot can cause staining or damage to food warmer finish.**
- Wipe the surface with a clean, damp cloth to remove fingerprints, dust, etc.
- Spray with a light coating of glass cleaner to remove grease or other dirt. Use a non-ammonia cleaner.
- Be sure not to spray any cleaning product directly into the bulbs, fixtures or heating elements.

IDENTIFYING YOUR PRODUCT

Each BSI light, warmer or combo unit contains an Identification Sticker. This sticker provides the customer with the following information:

- Serial Number
- Model Number
- Manufacture Date
- Electrical Information

Sample Stealth Warmer Sticker with everything you need to know about your unit.



CHANGING THE FLUORESCENT BULB

When a fluorescent bulb burns out and needs to be replaced you will need to do the following:

- Turn off power to all lights and warmers.
- Carefully push the white lever to the opposite side, rotating the bulb 90°.
- Rotating the lever will unlock the bulb. The pins will now be visible through the open slots at each end. Caution: At this position, bulbs are free to fall down through open slots.
- If the bulb does not easily slide out from the holders, tap lightly on housing first, then carefully use needle-nose pliers to grab the bulb, evenly pulling it down and out.
- Once the defective bulb is removed, remove the white lever end cap from the bulb prongs and proceed to place it on the new bulb prongs.
- With the new bulb in hand, evenly push the pins on both ends up and into the open slots of the lamp holders.
- Carefully push the white lever to the opposite side, rotating the bulb 90° and locking it into place. Pins will no longer be visible.

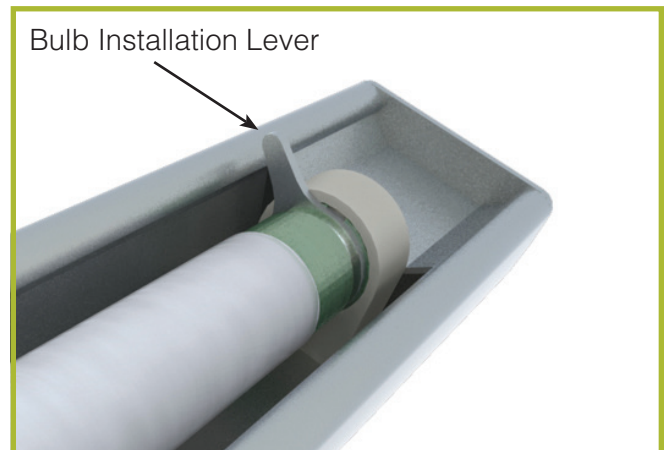

Do not use high-output bulbs.
Use coated, shatter-proof bulbs.

❖ CHANGING THE LED BULB

When a LED bulb burns out and needs to be replaced you will need to do the following:

- Turn off power to all lights and warmers.
- Carefully unscrew the end plate and slide out the entire LED light.
- If multiple lights are connected to each other carefully disconnect Serial Connector or Power Connector.
- Once dead light is removed, replace with new LED light. Carefully reconnect the connector and slide in the light bar.
- Replace end cover and the two screws.

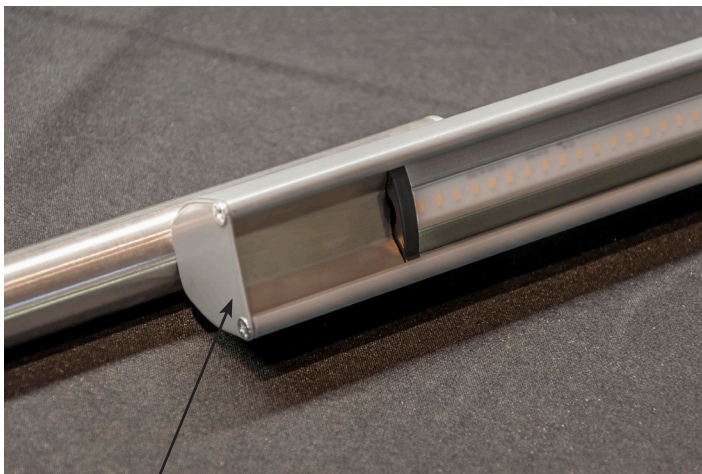

End Plate

❖ PARTS & SERVICE

In the event that your Lights or Warmers need service and require major repairs, contact your local installer for assistance.

If you have questions about the products or need to replace minor parts you may contact BSI, LLC at 1.800.662.9595.

❖ ORDERING NEW FLUORESCENT BULBS

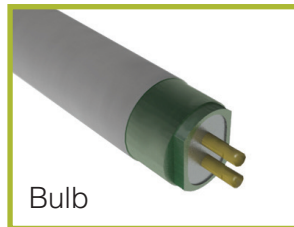

Bulb



Bulb
Installation Lever

<i>Part #</i>	<i>Description (All bulbs 4100K)</i>
508-8-C	F8-T5/CW - 12" Long
508-14-C	F14-T5/CW - 22" Long
508-21-C	F21-T5/CW - 34" Long
508-28-C	F28-T5/CW - 46" Long
508-35-C	F35-T5/CW - 58" Long
512	Bulb Installation Lever

❖ ORDERING NEW LED LIGHTS

<i>Part #</i>	<i>Description</i>
16289	Kelly LED:_12"_LED_Light_Bar
16290	Kelly LED:_18"_LED_Light_Bar
16292	Kelly LED:_36"_LED_Light_Bar
16505	Kelly LED:_48"_LED_Light_Bar
16293	Kelly LED:_10'_Power_Cord_w/o_Plug
16294	Kelly LED:_Serial_Connector
16295	Kelly LED:_6" Power_Connector

REPLACING THE TUBULAR HEATING ELEMENTS

On all three Stealth Warmer units the tubular heating element can burn out, similar to a light bulb.

Replacing the tubular heating element should be completed by a Professional Service Technician. If you have additional questions please contact BSI at 1.800.662.9595.

ORDERING NEW HEATING ELEMENTS

Part #	Description
492-18-BK	Element:_18"_120V_Heater_350W
492-24-BK	Element:_24"_120V_Heater_500W
492-30-BK	Element:_30"_120V_Heater_660W
492-36-BK	Element:_36"_120V_Heater_800W
492-42-BK	Element:_42"_120V_Heater_950W
492-48-BK	Element:_48"_120V_Heater_1100W
492-54-BK	Element:_54"_120V_Heater_1250W
492-60-BK	Element:_60"_120V_Heater_1400W
492-66-BK	Element:_66"_120V_Heater_1560W

Part #	Description
496-24-BK	Element:_24"_208V_Heater_500W
496-30-BK	Element:_30"_208V_Heater_660W
496-36-BK	Element:_36"_208V_Heater_800W
496-42-BK	Element:_42"_208V_Heater_950W
496-48-BK	Element:_48"_208V_Heater_1100W
496-54-BK	Element:_54"_208V_Heater_1250W
496-60-BK	Element:_60"_208V_Heater_1400W
496-66-BK	Element:_66"_208V_Heater_1560W

240V Heat Elements are a Special Order Item. Contact BSI at 1.800.662.9595 to place an order.

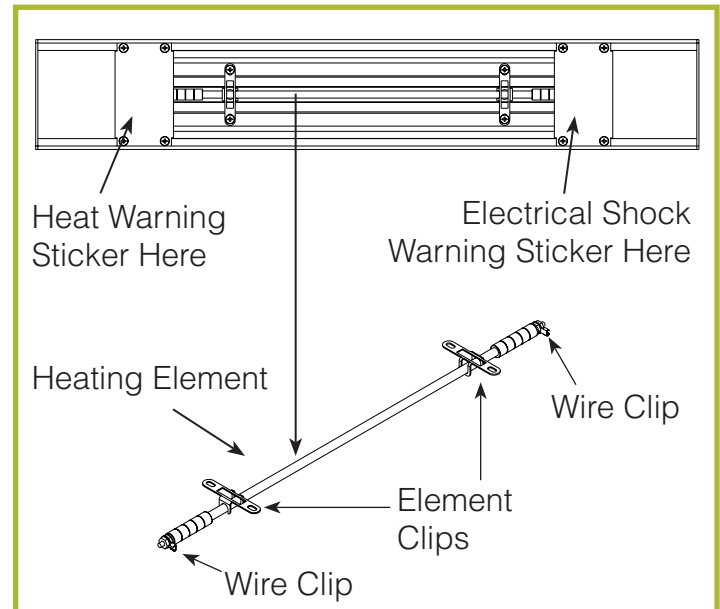

WIRING INSTALLATIONS

Fluorescent Light/Stealth™ Warmer Combo

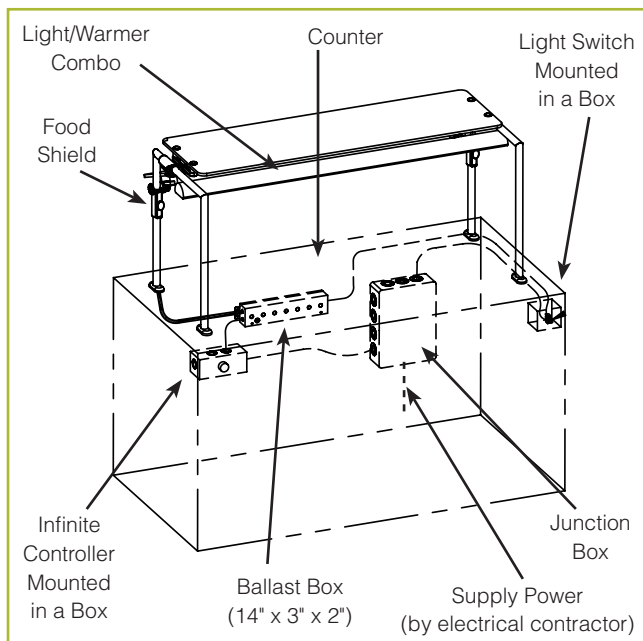

LED Light/Stealth™ Warmer Combo

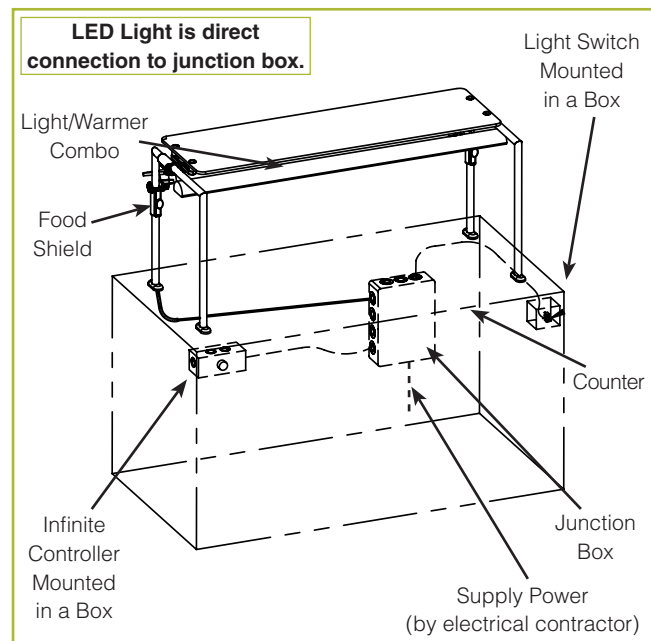

Stealth™ Warmer Combo Heat Light Heat (Fluorescent)

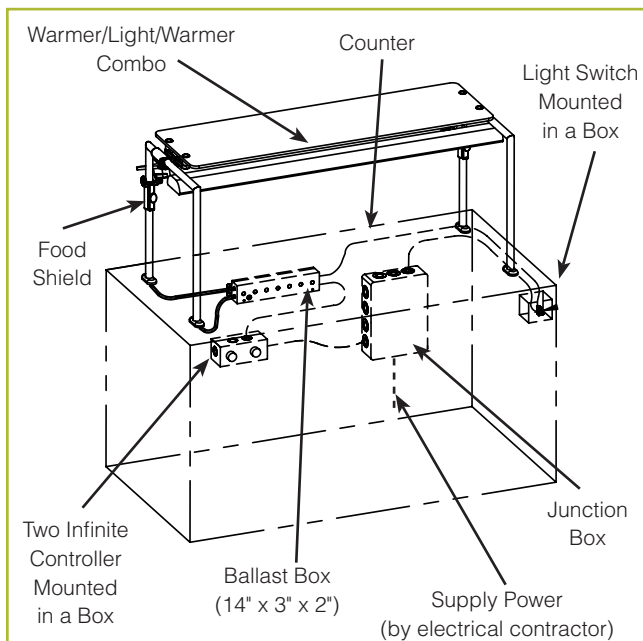

Stealth™ Warmer Combo Heat Light Heat (LED)

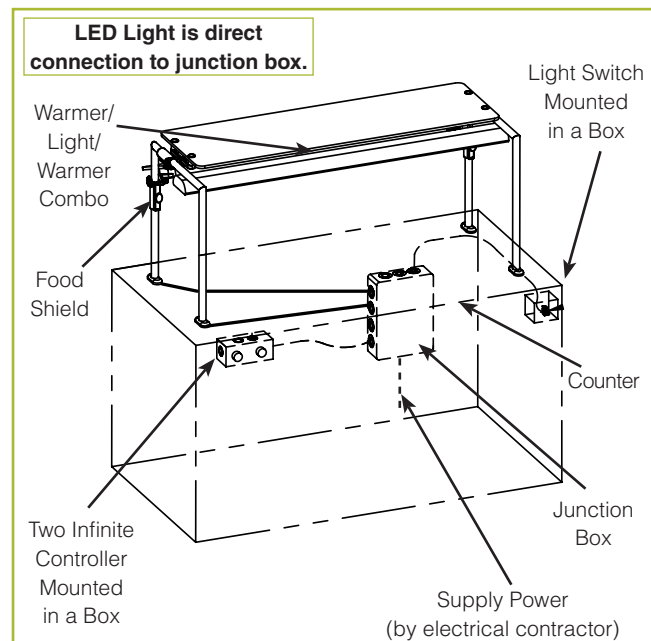

Typical Food Shield Light and Warmer Installations

- All wiring should be performed by a certified technician.
- Wires are routed through wire chase/support legs per approved shop drawings.
- Mount the ballast box, infinite controllers near the wire chase/support leg.
- The ballast box, infinite controllers, light switch and 6 feet of conduit/wiring exiting support legs are all provided with all models of BSI, LLC Food Shields. All other components are provided by others.

WIRING INSTALLATIONS

Fluorescent Lights

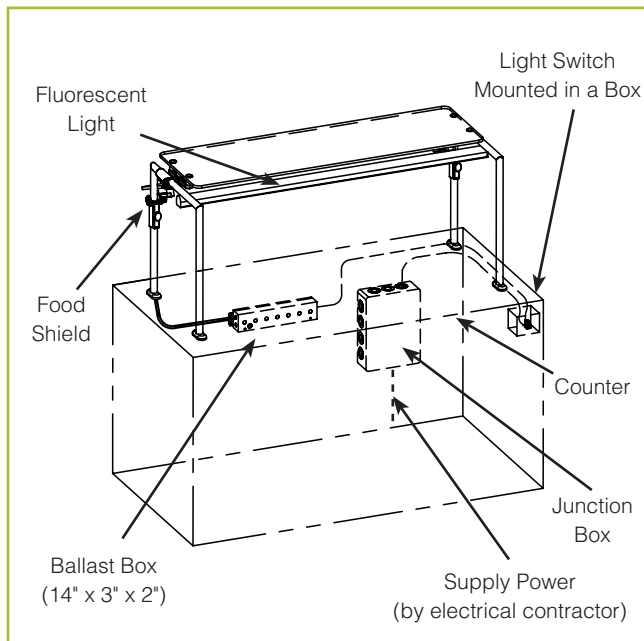

LED Lights

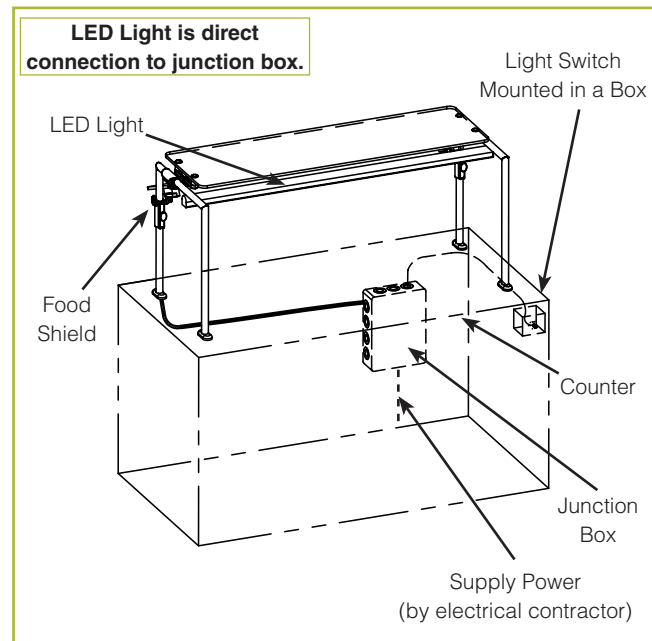

Stealth™ Warmer

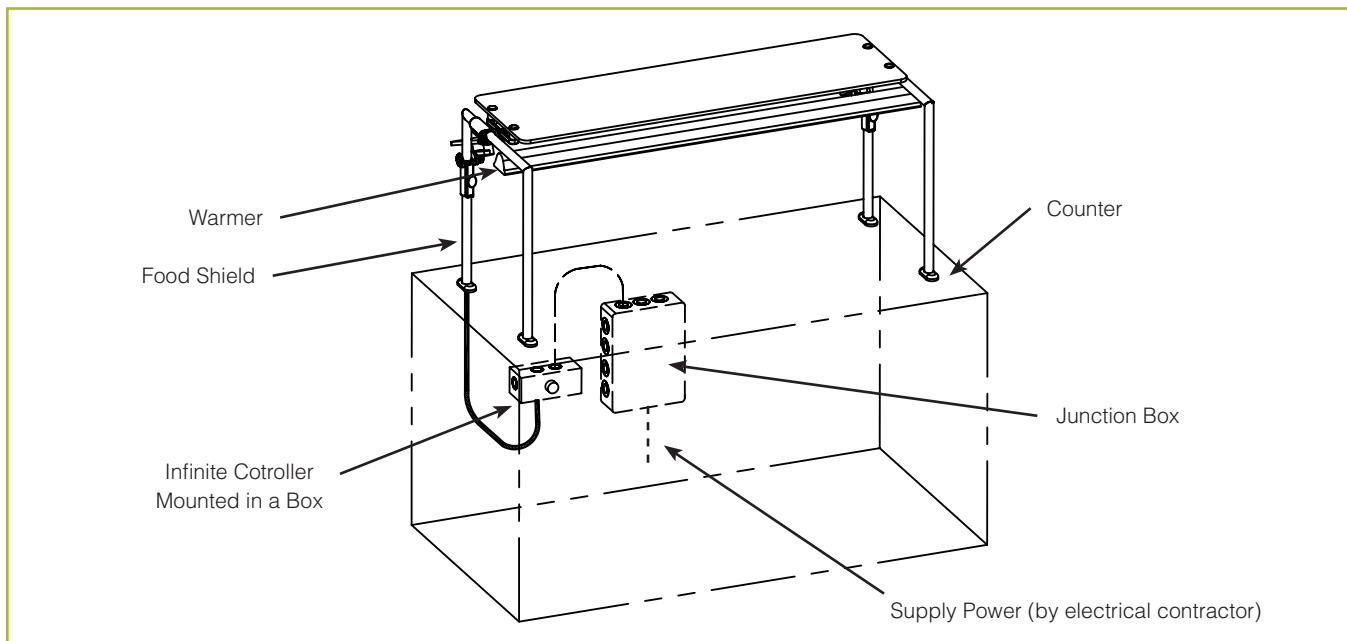

Typical Food Shield Light and Warmer Installations

- All wiring should be performed by a certified technician.
- Wires are routed through wire chase/support legs per approved shop drawings.
- Mount the ballast box, infinite controllers near the wire chase/support leg.
- The ballast box, infinite controllers, light switch and 6 feet of conduit/wiring exiting support legs are all provided with all models of BSI, LLC Food Shields. All other components are provided by others.

WIRING DIAGRAMS

Remote Infinite Control for Stealth™ Warmer/Combo Units

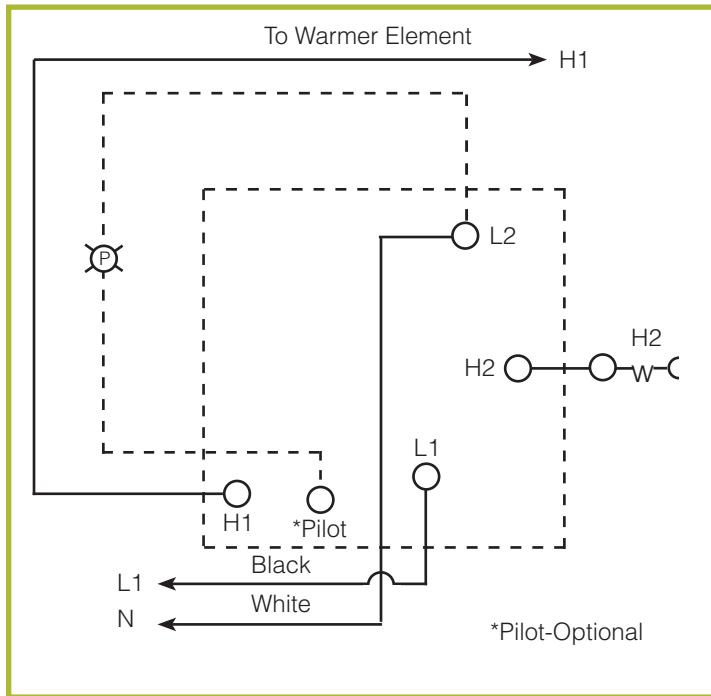

INFINITE SWITCH (120V) - PART #581

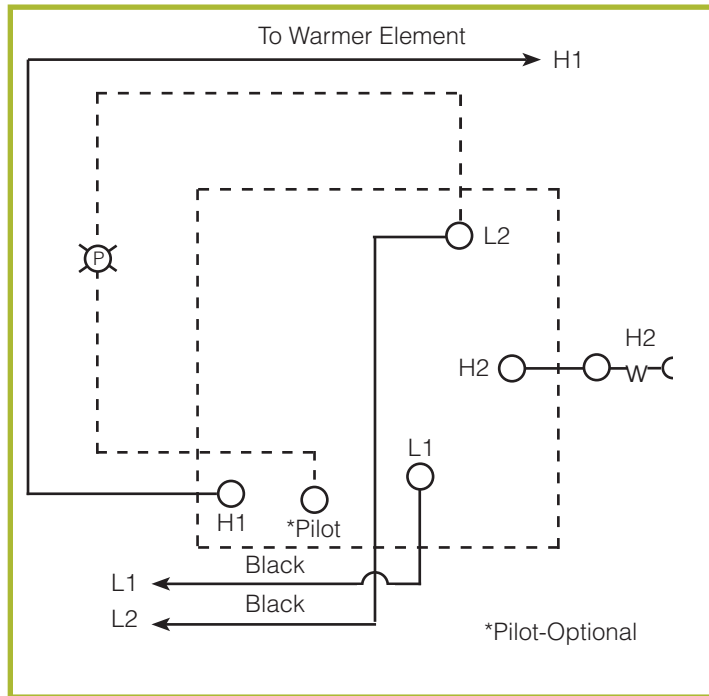

INFINITE SWITCH (208V/240V) - PART #582

FLUORESCENT LIGHT BALLASTS



As a standard, all BSI fluorescent lights are supplied with a remote ballast (internal ballasts are available). This UL Listed ballast is supplied in a UL approved box that needs to be located and installed below the counter.

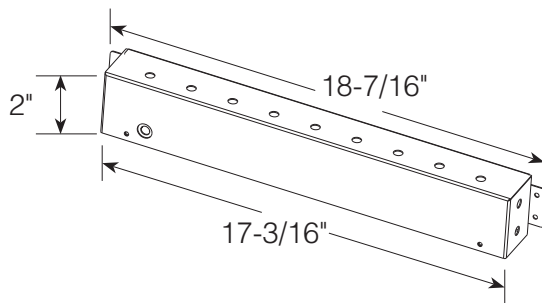

Ballast Box for
 LH1 - Part #509-1 & LH2 - Part #509-2
 LH4 - Part #509-4

DIAGRAMS FOR FLUORESCENT LIGHTS AND LIGHT/WARMER COMBO UNITS

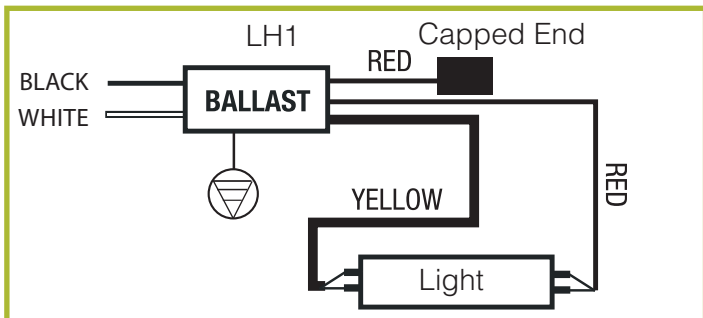

LONGHORSE 1 - LINEAR

On Stealth Heat/Light Combo

Description	Lamp Type
16"-18" T5 Fluorescent Fixture	F6 / T5
19"-27" T5 Fluorescent Fixture	F8 / T5
28"-39" T5 Fluorescent Fixture	F14/T5
40"-51" T5 Fluorescent Fixture	F21/T5
52"-62" T5 Fluorescent Fixture	F28/T5

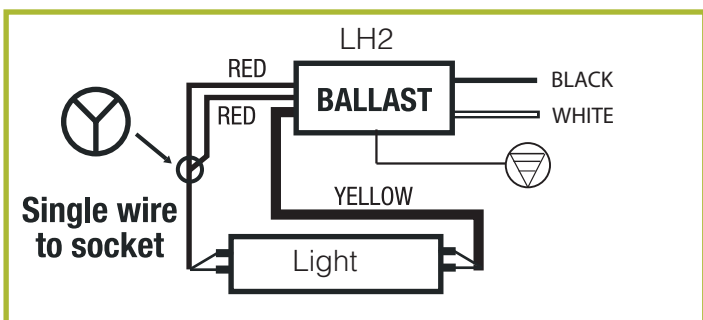

LONGHORSE 2 - LINEAR

On Stealth Heat/Light Combo

Description	Lamp Type
65"-74" T5 Fluorescent Fixture	F35 / T5

LONGHORSE 2 - LINEAR

On Stealth Heat/Light Combo

Description	Lamp Type
75"-86" T5 Fluorescent Fixture	(2) F21 / T5

This is the LH2 Ballast but is wired like an LH4.

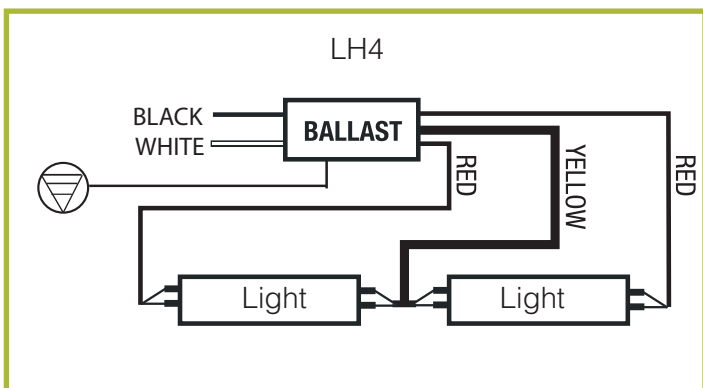

LONGHORSE 4 - LINEAR

On Stealth Heat/Light Combo

Description	Lamp Type
87"-98" T5 Fluorescent Fixture	(1) F21 & (1) F28 / T5
99"-110" T5 Fluorescent Fixture	(2) F28 / T5
111"-121" T5 Fluorescent Fixture	(1) F28 & (1) F35 / T5
122"-144" T5 Fluorescent Fixture	(2) F35 / T5

BSI, LLC WARRANTY

BSI, LLC warrants its products to be free from defects in material and workmanship from the date of their original purchase for normal use and for the applicable warranty periods set forth below. BSI, LLC's warranty extends only to original purchasers acquiring new products purchased in the United States directly from BSI, LLC, its authorized dealers or other companies specifically authorized by BSI, LLC to act as resellers of its products.

ZGUARD

BSI, LLC warrants the ZGuard system against defects in material and workmanship for a period of two years from invoice date. This excludes glass chipping or breakage after installation that can be explained as "use and abuse".

STEALTH WARMERS

BSI, LLC warrants the Stealth Warmer against defects in material and workmanship for a period of two years from invoice date. The warming element is warranted for two years from invoice date.

FLUORESCENT LIGHT BALLAST

The Slimline Light warranty is for material and workmanship for the period of two years from invoice date. The fluorescent bulb itself is not covered under warranty.

LED LIGHT

The LED Light warranty is for material and workmanship for the period of two years from invoice date. The fluorescent bulb itself is not covered under warranty.

THERE ARE NO WARRANTIES EXCEPT AS EXPRESSLY STATED ABOVE, WHETHER EXPRESSED OR IMPLIED, INCLUDING, BUT NOT LIMITED TO, ANY WARRANTY OF MERCHANTABILITY OR FITNESS FOR ANY PARTICULAR PURPOSE. These warranties do not apply to any products which have been altered in any way or to products which have been subject to misuse, abuse, neglect, accident, or which have been damaged in transit. Warranty is void if products are used, held or stored in an unsupervised environment. BSI, LLC's liability for its products shall be limited to the repair or replacement of products or, at BSI, LLC's option, to refunding the purchase price. BSI, LLC will not be liable, under any circumstances, for incidental or consequential damages (including, without limitation, to lost profits) arising in connection with the sale, use, inability to use, repair or replacement of BSI, LLC's products. The liability of BSI, LLC arising from any cause shall not exceed the price paid for the products.

Any claim for breach of the foregoing warranties shall be deemed waived unless submitted to BSI, LLC in writing within 30 days of the date the alleged defect was discovered, or by reasonable inspection should have been discovered. The merchandise must be returned to the BSI, LLC factory from which it was purchased, freight prepaid, and will not be accepted unless prior written authorization to return the merchandise has been issued by BSI, LLC. A copy of the original invoice must accompany the returned merchandise to prove the date of original purchase and warranty entitlement. Any cause of action for breach of the foregoing warranties shall be deemed waived unless brought within one year of the date of the claim submission.

BSI, LLC

**601 E. 64th Ave., Blvd. A
Denver, CO 80229**

1.800.662.9595
www.BSIdesigns.com

