

GENERAL INFORMATION

Project Name: _____
Item: _____
Quantity: _____
Model: XG3500-4 _____
Length: _____

STANDARD NSF LISTED FINISH OPTIONS

- | | |
|---|--|
| <input type="checkbox"/> Brushed Aluminum | <input type="checkbox"/> Chrome |
| <input type="checkbox"/> Gloss Black | <input type="checkbox"/> Wrinkle Black |
| <input type="checkbox"/> Smoked Copper | <input type="checkbox"/> Polished Brass Finish |
| <input type="checkbox"/> Other _____ | |

GLASS THICKNESS

- 1/4" Tempered Glass (not for shelves)
Centerline Max 54"
- 3/8" Tempered Glass (for shelf or span more than 54")
Centerline Max 66"
- 1/2" Tempered Glass (for shelf or span more than 66")
Centerline Max 72"

GLASS CORNERS

- 1" Radius Corner (standard)
- Square Corners

INSTALLATION OPTIONS

Above-Counter: Stainless Steel Counter
Under-Counter: Stainless Steel Counter
 (Requires Under-Counter Reinforcement & Access)

Above-Counter: Millwork Counter

Under-Counter: Millwork Counter

See Installation Page for More Details.

XG3500-4 Operator-Serve and/or Partition

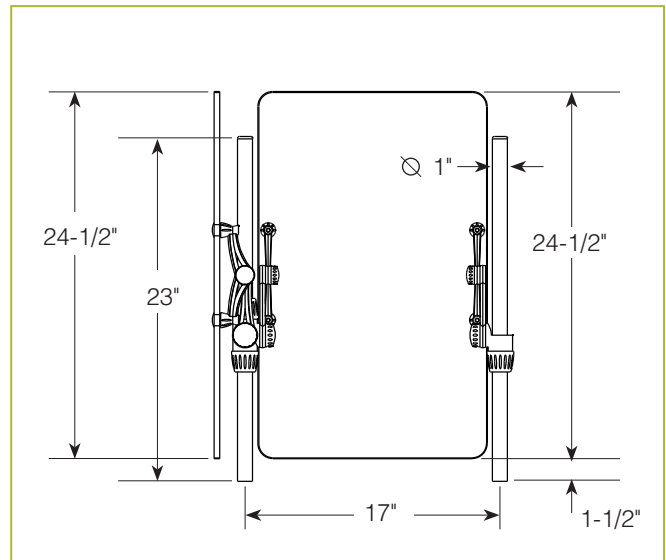
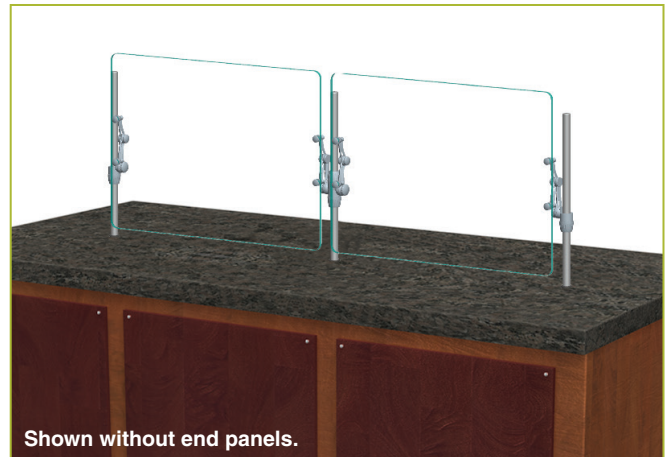

To meet NSF guidelines, end panels are included on all BSI quotations unless specifically excluded. (See End Panel Page for More Details.)

- SS1: EZ Mount 2" x 8" Flange
- SSU3-H: Heavy-Duty Flange
- SSU3-N: Narrow Flange
- SSU5-H: Heavy-Duty Flange
- SSU5-N: Narrow Flange
- MW1: Heavy-Duty Flange
- MW2: Narrow Flange
- MWU3: Narrow Flange
- MWU4: Compression Installation (not recommended for solid surfaces)
- MWU5: Heavy-Duty Flange

* Approval Drawings Required