

GENERAL INFORMATION

Project Name: _____
Item: _____
Quantity: _____
Model: XG3930-5
Length: _____

STANDARD NSF LISTED FINISH OPTIONS

- | | |
|---|--|
| <input type="checkbox"/> Stainless Steel #4 | <input type="checkbox"/> Chrome |
| <input type="checkbox"/> Gloss Black | <input type="checkbox"/> Wrinkle Black |
| <input type="checkbox"/> Smoked Copper | <input type="checkbox"/> Polished Brass Finish |
| <input type="checkbox"/> Other _____ | |

LIGHT AND WARMER OPTIONS

- LED Light Unit
- Linear T-5 Fluorescent Unit
- BSI Stealth™ Linear Heat Only Unit
- BSI Stealth™ Linear Heat and Light Combo Unit (Fluorescent)
- BSI Stealth™ Linear Heat and Light Combo Unit (LED)
- BSI Stealth™ Linear Double Heat and Light Combo Unit (Fluorescent)
- BSI Stealth™ Linear Double Heat and Light Combo Unit (LED)
- Hatco® Brand Heat Only Unit
- Hatco® Brand Heat and Light Combo Unit

GLASS THICKNESS

- 1/4" Tempered Glass (not for shelves)
Centerline Max 54"
- 3/8" Tempered Glass (for shelf or span more than 54")
Centerline Max 66"
- 1/2" Tempered Glass (for shelf or span more than 66")
Centerline Max 72"

GLASS CORNERS

- 1" Radius Corner (standard)
- Square Corners

INSTALLATION OPTIONS

Above-Counter: Stainless Steel Counter
Under-Counter: Stainless Steel Counter
 (Requires Under-Counter Reinforcement & Access)

Above-Counter: Millwork Counter

Under-Counter: Millwork Counter

See Installation Page for More Details.

XG3930-5 Two-Tier Display Case



Shown without end panels.

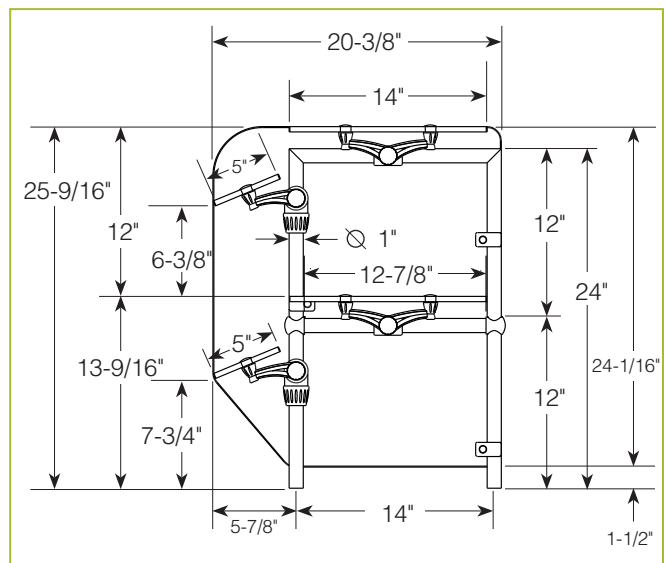

To meet NSF guidelines, end panels are included on all BSI quotations unless specifically excluded. (See End Panel Page for More Details.)

To meet NSF guidelines the upper tier will be labeled "For prepackaged food only".

- SS1: EZ Mount 2" x 8" Flange
- SSU3-H: Heavy-Duty Flange
- SSU3-N: Narrow Flange
- SSU5-H: Heavy-Duty Flange
- SSU5-N: Narrow Flange
- MW1: Heavy-Duty Flange
- MW2: Narrow Flange
- MWU3: Narrow Flange
- MWU4: Compression Installation (not recommended for solid surfaces)
- MWU5: Heavy-Duty Flange

* Approval Drawings Required

Specifications subject to change without notice.

Patent Number US 8,403,430 B2

5.21

XGuards can be provided with a UL Listed light or warmer.

