

## GENERAL INFORMATION

Project Name: \_\_\_\_\_  
 Item: \_\_\_\_\_  
 Quantity: \_\_\_\_\_  
 Model: ZG9930-2  
 Length: \_\_\_\_\_

## STANDARD NSF LISTED FINISH OPTIONS

- |   |  |
|---|--|
| <input type="checkbox"/> Stainless Steel #4 | <input type="checkbox"/> Chrome                |
| <input type="checkbox"/> Gloss Black        | <input type="checkbox"/> Wrinkle Black         |
| <input type="checkbox"/> Smoked Copper      | <input type="checkbox"/> Polished Brass Finish |
| <input type="checkbox"/> Other _____        |  |

## LIGHT AND WARMER OPTIONS

- LED Light Unit
- Linear T-5 Fluorescent Unit
- BSI Stealth™ Linear Heat Only Unit
- BSI Stealth™ Linear Heat and Light Combo Unit (Fluorescent)
- BSI Stealth™ Linear Heat and Light Combo Unit (LED)
- BSI Stealth™ Linear Double Heat and Light Combo Unit (Fluorescent)
- BSI Stealth™ Linear Double Heat and Light Combo Unit (LED)
- Hatco® Brand Heat Only Unit
- Hatco® Brand Heat and Light Combo Unit

## GLASS THICKNESS

- 1/4" Tempered Glass (not for shelves)  
Centerline Max 54"
- 3/8" Tempered Glass (for shelf or span more than 54")  
Centerline Max 66"

## GLASS CORNERS

- 1" Radius Corner (standard)
- Square Corners

## INSTALLATION OPTIONS

**Above-Counter:** Stainless Steel Counter  
**Under-Counter:** Stainless Steel Counter  
 (Requires Under-Counter Reinforcement & Access)

**Above-Counter:** Millwork Counter

**Under-Counter:** Millwork Counter

- SS1: EZ Mount 2" x 8" Flange
- SSU3-H: Heavy-Duty Flange
- SSU3-N: Narrow Flange
- SSU5-H: Heavy-Duty Flange
- SSU5-N: Narrow Flange
- MW1: Heavy-Duty Flange
- MW2: Narrow Flange
- MWU3: Narrow Flange
- MWU4: Compression Installation (not recommended for solid surfaces)
- MWU5: Heavy-Duty Flange

See Installation Page for More Details.

## ZG9930-2

Double-Sided w/Top Shelf



Shown without end panels.

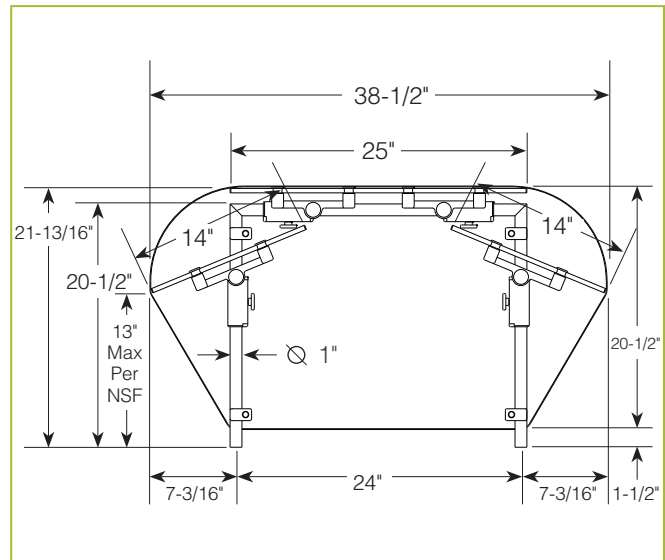

To meet NSF guidelines, end panels are included on all BSI quotations unless specifically excluded. (See End Panel Page for More Details.)

## \* Approval Drawings Required

ZGuards can be provided with a UL Listed light or warmer.

Specifications subject to change without notice.

Patent Number 6,588,863

5.22

