

**GENERAL INFORMATION**

**Project Name:** \_\_\_\_\_  
**Item:** \_\_\_\_\_  
**Quantity:** \_\_\_\_\_  
**Model:** CUSTOM BAR CART  
**Length:** \_\_\_\_\_

**STANDARD FEATURES**

- 16 gauge #304 stainless steel countertop
- Laminate exterior panels  
Stainless steel interior
- 6" casters, two (2) rigid and two (2) swivel with brakes
- Black rubber caster skirt on three (3) sides
- Open storage compartment for beverage system
- Stainless steel ice bin with drain and 7-1/2 gallon waste water tank
- Laminate bar top
- Removable speed rail
- All tanks, valves, piping and fittings to comply with all NSF, local, state and federal health codes and standards
- U.L. Listed
- NSF Listed to Standard 59

**OPTIONS**

- Custom panels (powder coated metal, wood veneer, stainless steel, etc.)
- Custom tops (corian, granite, etc)
- Diamond signage with graphics
- Rubber bumper
- Refrigerated power pack and support cart
- Post-mix system
- Pre-mix system
- Bottle and can rack

**ELECTRICAL REQUIREMENTS**

- 120Volt / 1 Phase / 15 Amp
- Optional convience outlet, otherwise no power

**CUSTOM BAR CART**  
6' Cart

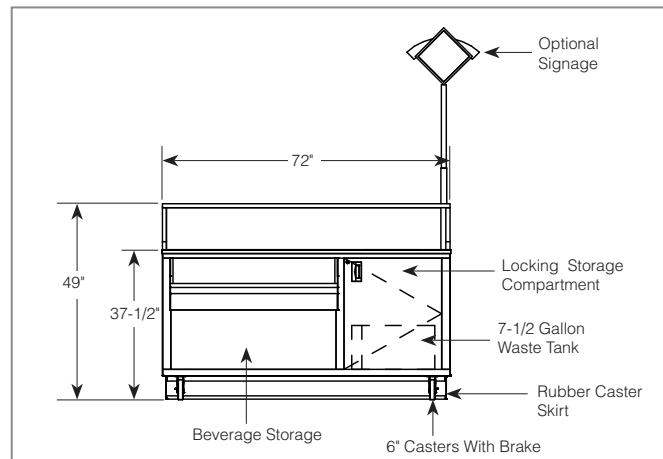
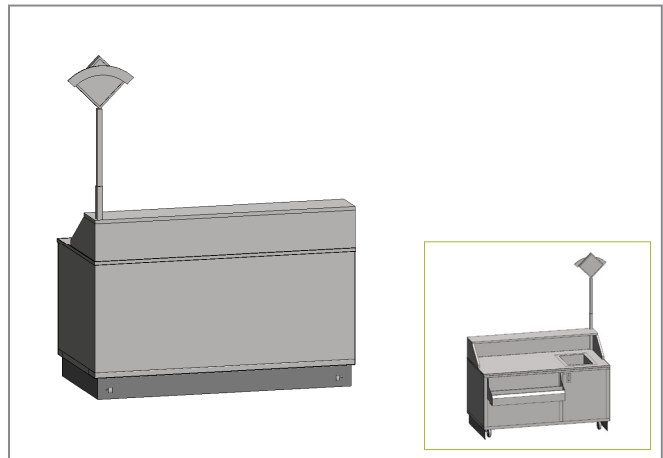

All fixtures and equipment to be connected to a single load center. Cart to have one (1) 8' power cable with a NEMA 5-15P plug.

**PLUMBING PROVIDED**

Ice bins to drain to a ball valve located below the cart.