

## GENERAL INFORMATION

Project Name: \_\_\_\_\_  
 Item: \_\_\_\_\_  
 Quantity: \_\_\_\_\_  
 Model: ZG9945-4  
 Length: \_\_\_\_\_

## STANDARD NSF LISTED FINISH OPTIONS

- Stainless Steel #4
- Chrome
- Gloss Black
- Wrinkle Black
- Smoked Copper
- Polished Brass Finish
- Other \_\_\_\_\_

## LIGHT AND WARMER OPTIONS

- LED Light Unit
- Linear T-5 Fluorescent Unit
- BSI Stealth™ Linear Heat Only Unit
- BSI Stealth™ Linear Heat and Light Combo Unit (Fluorescent)
- BSI Stealth™ Linear Heat and Light Combo Unit (LED)
- BSI Stealth™ Linear Double Heat and Light Combo Unit (Fluorescent)
- BSI Stealth™ Linear Double Heat and Light Combo Unit (LED)
- Hatco® Brand Heat Only Unit
- Hatco® Brand Heat and Light Combo Unit

## GLASS THICKNESS

- 1/4" Tempered Glass (not for shelves)  
Centerline Max 54"
- 3/8" Tempered Glass (for shelf or span more than 54")  
Centerline Max 66"

## GLASS CORNERS

- 1" Radius Corner (standard)
- Square Corners

\* Maximum span between legs on counter is recommended at 78".

## INSTALLATION OPTIONS

### Above-Counter

- Surface Installation 720A/726A: Steel Post and Flange w/Flange Cover

### Under-Counter

- Surface Installation 725A: Cut Flange
- Under-Counter Installation 720A/726A: Steel Post and Flange w/Flange Cover or w/out Flange Cover
- Under-Counter Installation 725A: Narrow Custom Flange

(Requires Under-Counter Reinforcement & Access)

See Installation Page for More Details.

## ZG9945-4

### EZ Span Two-Tier, Self-Serve w/Top Shelf



Shown without end panels.

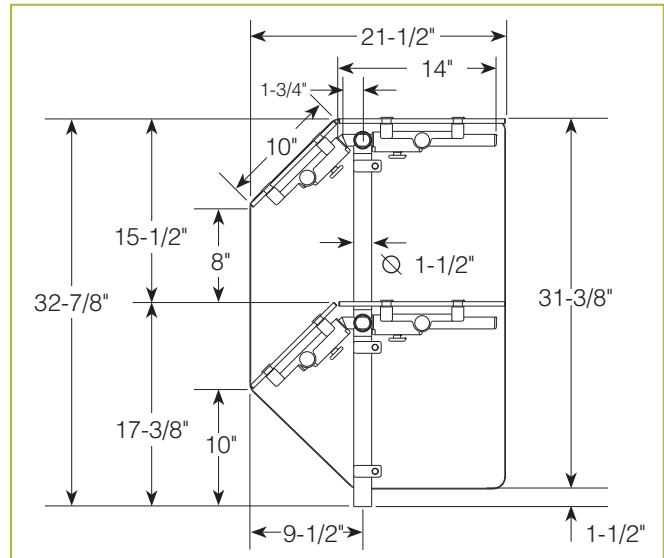

To meet NSF guidelines, end panels are included on all BSI quotations unless specifically excluded. (See End Panel Page for More Details.)

## \* Approval Drawings Required

ZGuards can be provided with a UL Listed light or warmer.